

FUN*da*MENTALS of Design

Topic 8 Structures

Structures

Take a close look at a bridge or a building as it is being built and compare what you see to the structure of a large crane, automobile, or machine tool. What commonalities and differences do you observe? Many structures meet their functional requirements by taking advantage of fundamental principles such as the Parallel Axis Theorem which motivates designers to increase strength or stiffness by placing the mass away from the neutral axis. In fact, in order to become good at designing structures, or anything for that matter, you have to become good at observing structures!¹

The design process for a structure is just like the design process for an entire machine: Functional requirements must be defined, and then Design Parameters are envisioned. Analysis provides insight to what might be the most efficient design, but history (references) often plays an important role in catalyzing ideas. There will always be risks associated with structures as in general it is desired that they be as light as possible, at least for airplanes and robots. And where there are risks, there must be countermeasures, such as adding a

diagonal brace or increasing the stiffness of a plate by making it into a laminate.

In fact, one of the greatest risks in the design of structures is that the desire for cost savings will lead to a structure that is strong but not stiff. A common example is the floor of a house, which is strong, but it bounces and things rattle when you walk across it. Another example is plastic lawn furniture which can be strong but feels wobbly. In machines, this “lawn furniture effect” means that the structure is too compliant and when loads are placed on it, it bends and sags. This can cause bearings and other components to become loaded in ways in which they were not intended.

Accordingly, this chapter will focus on designing structures to meet functional requirements. Included will be consideration for how structures are manufactured and the implications for design.

1. As part of this book's continuing pursuit of personal happiness, if you are interested in someone, but not sure how to ask them out, invite them to go look at structures with you! There are few spectator sports as exciting as looking at the details of bridge construction, crane booms, or the erection of steel structures!

Topic 8 Structures

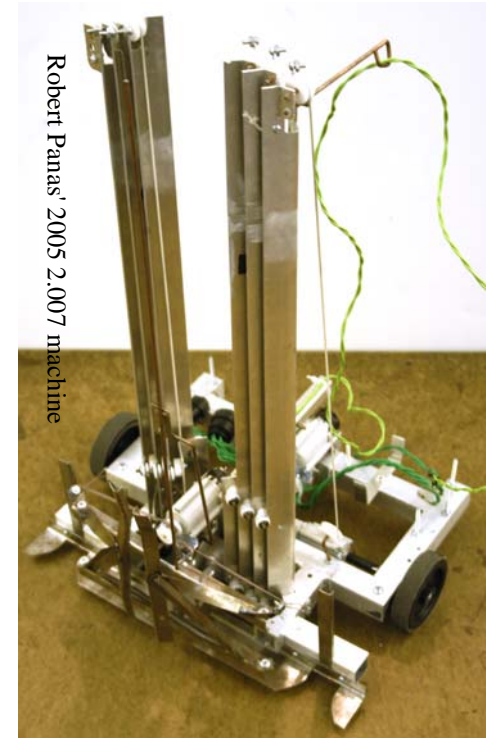
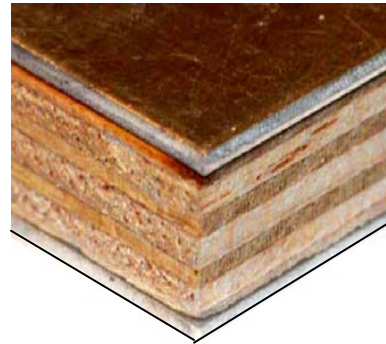
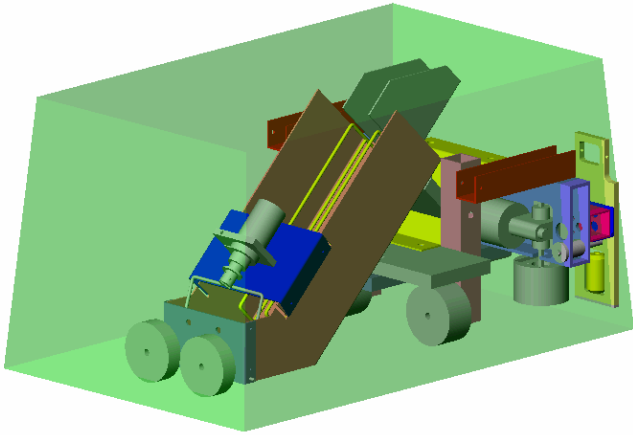

Robert Panas' 2005 2.007 machine



Topics

- Beginnings
- **FUNdaMENTAL** Principles
- Materials
- Visualization
- Layout
- Stability
- Loadings
- Stiffness
- Strength
- Trusses
- Laminates & Composites

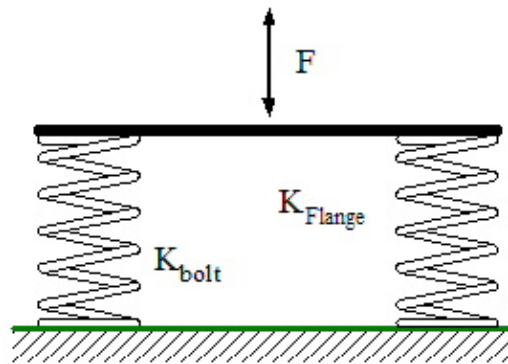
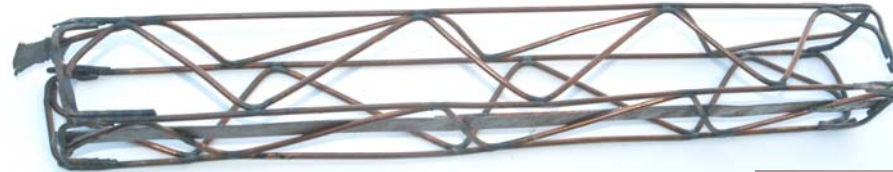

Bryan Ruddy's most amazing Lazy-Tongs structure (2001)

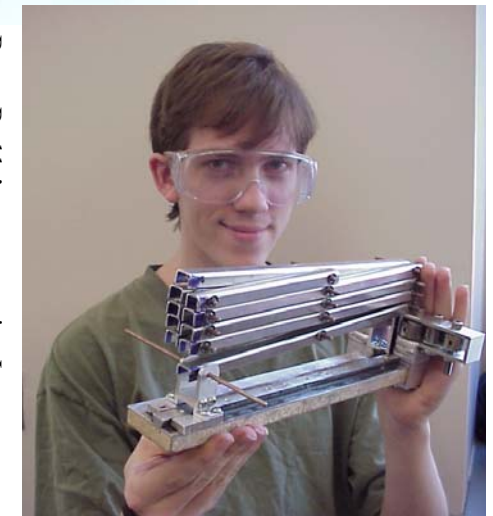

Beginnings

The design process starts with development of a strategy and ends with components as outlined by FRDPARRC tables (see Chapter 1). Just as the design process RepeatsRepeatsRepeatsRepeats, so it is with structures: Everything has a structure:

- The overall system
- The modules
- The components

In order to train your mind to synthesize structures, start by observing the world around you. Look at your bicycle and try to see how the frame achieves its primary function of supporting your weight, while also providing support and mounting points for other components. Open a car's doors, hood, and trunk, and identify the major structural features that support the overall car, while also providing mounting points for other components. How is the engine mounted? What are the implications for safety? Car designers realized that given a velocity V , the acceleration to slow down in a distance x is

$$v = at \quad x = \frac{1}{2}at^2 \Rightarrow v = \sqrt{2ax} \Rightarrow a = \frac{v^2}{2x}$$

If the structure between the bumper and the passenger could be made to crumple upon impact, the passenger compartment would have time to slow down and hence subject the driver to lower acceleration and less force. These types of first-order calculations associated with the functional requirements, such as keeping the passenger safe, are a vital part of creating a structure.

The philosophical aspect of analysis is perhaps even more important, for it is a catalyst to creative thought. If you perfectly develop the detailed design of a poor structural concept, then the result will be a detailed piece of junk. Selecting the best initial concept, such as one where the center of stiffness and mass are coincident, sets you up to do the detailed design on a great concept, and you can have a great machine. Hence before proceeding further, review the following list of **FUNdaMENTAL** principles that were discussed in detail in Chapter 3. Can you see images in your mind that illustrate each of

these principles? How many of the following do you really recall and understand?

- Occam's Razor: KISS & MISS
- Newton & Conservation
- Saint-Venant's Principle
- Abbe's Principle
- Maxwell's Reciprocity
- Self-Principles
- Stability
- Superposition
- Golden Rectangle
- Parallel Axis Theorem
- Accuracy, Repeatability, Resolution
- Sensitive Directions
- Reference Features
- Structural Loop
- Free Body Diagram
- Centers of Action
- Exact Constraint Design
- Elastic Averaged Design
- Stick Figures

Being able to associate images with fundamental principles can enable you to recall them to form foundations or starting points for your new design. Similarly, whenever you see a structure, scan through the fundamental principles and store an image of what you have seen with the appropriate principle. Store both good and bad images, because there are a lot of poorly designed products that make it to the marketplace. This can happen because a big company pushed a product through on the basis of its name, or the product has new and unique features that make people want it, but it was just poorly executed (and waiting for a competitor to fix and take market share!).

On the basis of your initial sketch of your best concept, cycle through the fundamental principles and make sure you are not violating any. If you are, do appropriate analysis to see if the design might still be OK. Remember, principles are guidelines and with appropriate deterministic analysis, they can be applied appropriately and creatively.

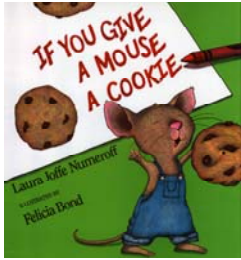

Rony Kubat's most professional
2.007 machine EVER!

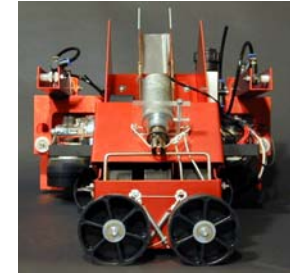

Beginnings

- People have always sought to create ever larger, more complex structures
 - A structure might be able to hold its own weight, but then how much of a load could it carry?
- Bridges represent the greatest structural challenges:
 - Whenever a longer bridge was needed, adding more material also increased the weight...
 - <http://www.bizave.com/portland/bridges/Bridge-Gallery1.html>
http://www.discovery.com/stories/technology/buildings/brdg_explore.html#photo
- The great mathematicians of the 18th century set their minds to the task of developing mathematical formulas for predicting the strength of structures
 - See Stephen Timoshenko, *History of Strength of Materials*
- History often repeats itself (Patterns!)
 - Your machine has limited size & weight, yet you want your machine to reach out to the world

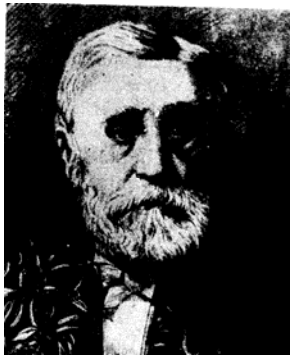

Barré de Saint-Venant
1797-1886



Leonhard Euler
1707-1783

John McBean's longest 2.007 truss ever!

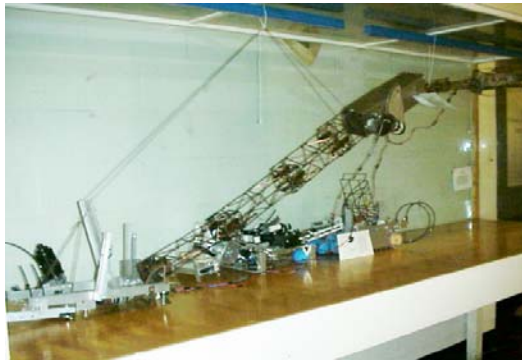

Stephen Prokofyevich Timoshenko
(1878-1972)

http://smitu.cef.spbstu.ru/timoshenko_en.htm

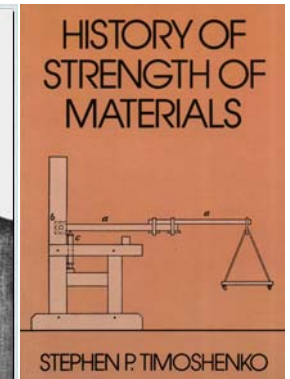

1/1/2008

FUNDaMENTAL Principles

The process of creating a machine's structure starts with drawing a stick figure of the machine's structural loop. Principle problems are typically encountered due to Abbe or sine-error effects, and then appropriate changes in geometry can be implemented, or the stiffness can be increased by proper selection of components or bracing. Creating the structure requires the designer to be acutely aware of the rest of the machine's components while always keeping in mind the fundamental principles which were discussed in detail in Topic 3. In quick review:

- **Occam's Razor:** This is what layout is all about, keeping things simple to start and adding detail as the design develops.
- **Newton and Conservation:** Action and reaction, free-body-diagrams, work in = work out... The basics come first before the details!
- **Saint-Venant's Principle:** When an object is to be controlled, sketch it being held at points several characteristic dimensions apart.
- **Golden Rectangle:** Don't know what size it should be? Start with a ratio of about 1.6:1.
- **Abbe's Principle:** Small angular deflections are amplified by distance to create large linear displacements (which can be good or bad).
- **Maxwell & Reciprocity:** Uncomfortable with a design? Try inverting it, or turning it on its side.
- **Self-Principles:** Use an object's geometry or other property to prevent a problem, like using a tapered plug to withstand pressure, or preventing overextension of a spring with the use of a hard-stop or a string in parallel.
- **Stability:** Stable, neutrally stable, and unstable effects can help or hurt. Triggers, for example, can be made neutrally stable and fast. Vibration can induce instability to get objects to come out of a bin... Beware of buckling of torsion and compression members!
- **Symmetry:** Try a design that is symmetric, and then impose *Reciprocity* to consider a design that is not symmetric...
- **Parallel Axis Theorem:** Add mass away from the neutral axis to increase strength and stiffness.
- **Accuracy, Repeatability, Resolution:** Make your machine repeatable first, then tune for accuracy if you have fine enough resolution: Tell the same story each time, the correct story, and with enough detail so people can understand it.
- **Sensitive Directions & Reference Features:** Why pay for performance in a direction that is not needed? Establish reference planes (datums) from which you measure critical parameters.
- **Structural Loops:** Draw a line through the path that forces follow, and seek to minimize its length. If the path length and shape changes significantly as the machine moves, then the machine will have limited accuracy and may have limited repeatability. Of particular note is the double disk grinding machine which uses the *symmetry* of a closed loop to minimize Abbe or sine error effects!
- **Free Body Diagrams & Superposition:** To analyze a complex object, separate it into its parts and label the forces and moments on each part that are imposed by other parts.
- **Preload:** Loose fits between objects mean you cannot predict where one object will be with respect to the other. Apply loads between the objects as part of manufacturing and assembly to take out the slack in the system.
- **Centers of Action:** If forces are applied through the centers of mass, stiffness and friction, there will be no moments and hence minimal Abbe and sine errors.
- **Exact Constraint Design:** The number of points at which a body is held/supported should be equal to the number of degrees of freedom that are to be restrained.
- **Elastically Averaged Design:** Hold/support a body with ten times (or more) more compliant points than there are degrees of freedom to be restrained, such that the errors in the compliant support points will average out.
- **Stick Figures:** Initially sketch an idea using simple stick figures, which also denote where major coordinate systems are located in the design. The coordinate system are to be used for modelling individual modules (e.g., for creating an error budget to predict a machine's repeatability & accuracy).

Think about your design concept and cycle through all these fundamental principles to see how they relate to your design. Remember, they are principles, not laws, and hence they should serve as catalysts and guidelines. If you want to not abide by one, make sure you have done the appropriate analysis or experiment to validate your hypothesis.

FUNdaMENTAL Principles

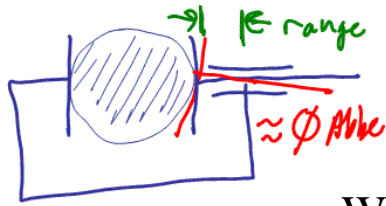

- When the first sketch of the structure is made:

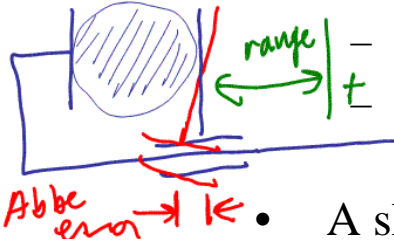

- Arrows indicating forces, moments, and power should also be sketched
- The path of how these forces and moments flow from the point of action to the point of reaction, shows the *structural loop*

- A sketch of the structural loop is a great visual design aid

- A closed structural loop indicates high stability and the likely use of symmetry to achieve a robust design
- An open structural loop is not bad, it means “proceed carefully”
- Remember Aesop’s fables & “The Oak Tree and the Reeds”

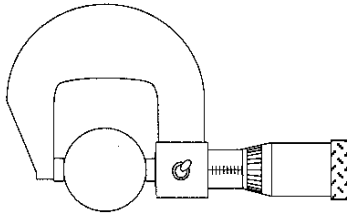

- Example: automobiles to disk drives to semiconductors, exist because of double-disk grinders’ ability to create parallel flat surfaces:

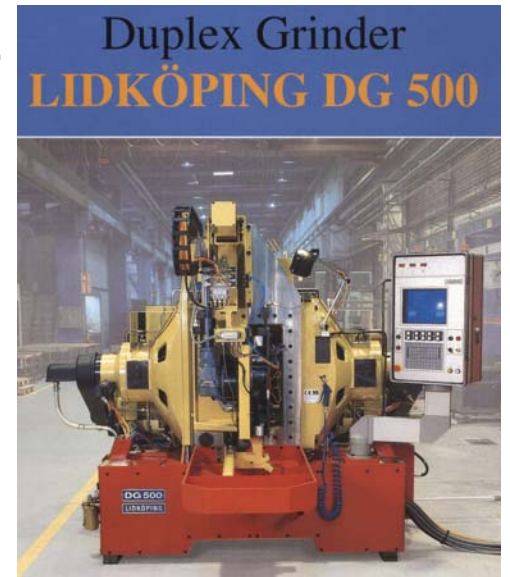
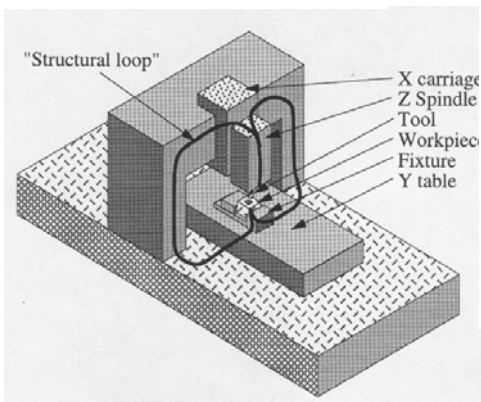
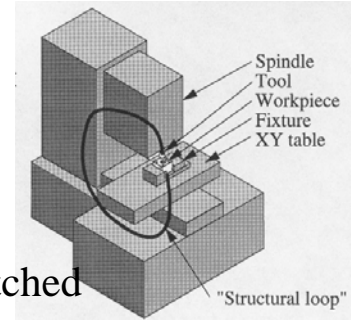
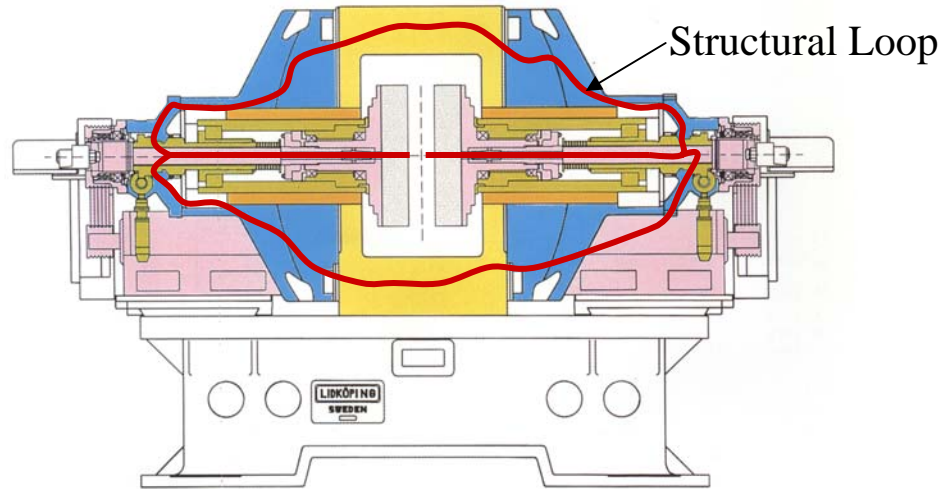
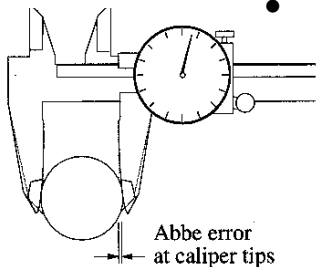

Materials

A structure is only as good as the materials and manufacturing processes used. Different materials often motivate the use of different types of manufacturing methods, which affects the design of the structure. For example, if the functional requirements of the structure include high stiffness, so deformations will not affect component alignment and function, a high modulus of elasticity material can be desirable. A metal shape with a large cross-sectional moment of inertia might be best. However, an additional functional requirement, such as to provide a large planer surface on which components can be mounted, could make creating the structure just from metal very challenging if the weight were to be kept reasonable. In this case, a ribbed or laminated structure might be best. *The decision as to what is best will often be cost driven. Different applications have different costs. For automobiles, save a kilogram and save \$1. For airplanes, save a kilogram and save \$100. For spacecraft, save a kilogram and save \$10,000!*

Materials generally fall into three classes: *structural*, *aesthetic*, and *hybrid*. Structural materials must withstand loads. Aesthetic materials act as coverings that look and/or feel good, but do not have to withstand significant loads. *Hybrids* must look and feel good and also perform a structural function. For example, the windows on your car have been shaped to look good, but they also have to reduce drag and withstand wind forces and minor impacts. Structural materials can be further divided into those which are *rigid* and those which are *compliant or resilient*. Both must have long life under load, but their degree of stiffness helps them to meet the intended functional requirements.

Hooke's law defines a linear isotropic material's behavior:

$$\epsilon_x = \frac{\sigma_x - \nu(\sigma_y + \sigma_z)}{E} + \alpha\Delta T$$

$$\epsilon_y = \frac{\sigma_y - \nu(\sigma_x + \sigma_z)}{E} + \alpha\Delta T$$

$$\epsilon_z = \frac{\sigma_z - \nu(\sigma_x + \sigma_y)}{E} + \alpha\Delta T$$

$$\gamma_{xy} = \frac{\tau_{xy}}{G} \quad \gamma_{xz} = \frac{\tau_{xz}}{G} \quad \gamma_{yz} = \frac{\tau_{yz}}{G} \quad G = \frac{E}{2(1+\nu)}$$

Hooke's law relates the strain, which is the ratio of the deformation to the length of the component (or the stress divided by the modulus of elasticity), to the stress, which is the ratio of the force to the area. An important issue is that when stress is applied to an object in the X-direction, for example, there is deformation in the X-direction and the Y and Z directions as well (squeeze a soft object to see this effect). This *poisson* effect, and hence the term *Poisson's ratio* ν , is a critical effect for bearings where tightening of bolts can cause bulging of features which then cause overloading of the bearings! In addition, Hooke's law also includes a term for the thermal expansion of the material: the product of the coefficient of thermal expansion α or CTE, and the change in temperature ΔT . Hooke's law also relates the torsional strain to the applied torque and the shear modulus. The shear modulus and the modulus of elasticity are also related by the poisson ratio ν .

The *ductility* of a material, which is a measure of the resistance to fracture, is the elongation which is the amount (%) that a material deforms before it fails. The *fracture toughness* is a measure of how easily cracks can grow in the material. The *brittle-to-ductile transition temperature* is the temperature where a marked increase in toughness occurs. In general, body-centered-cubic materials (e.g., ferritic steels) are susceptible to cold-temperature embrittlement. Face-centered-cubic materials (e.g., aluminum and austenitic stainless steels) typically do not suffer this loss of ductility.

The *ultimate strength* is the stress at which the material breaks. The *yield strength* is the stress at which the material can be subjected to with suffering from permanent deformation. The *fatigue strength* or *endurance limit* is the stress to which the material can be subjected for many cycles without failing. The *tensile*, *flexural (bending)*, and *compressive* strengths are generally the same for a metal. Brittle materials, such as glasses, ceramics, and concrete, are much stronger in compression than in tension, because the smallest crack in tension in a brittle material will grow rapidly. Plastics, rubbers, and woods also have different tensile, flexural, and compressive strengths, but when just their strength is quoted, the default is the lowest and hence limiting value.

Feel the stiffness of each of the materials in your kit. Perform inclined plane coefficient of friction tests between all your kit materials and between the kit materials and the contest table surfaces. What would work best for what functional requirements?

Materials

- Materials make the machine just as sure as any creative design, and are often selected based on strength, stiffness, manufacturability, and wear and corrosion resistance
 - Metals have very high strength-to-weight ratios and are easily machined formed, and joined
 - Wood has high directional strength/weight and is easily joined
 - Plastics can have good structural and low friction & wear-resistant properties and are easily molded, formed, machined

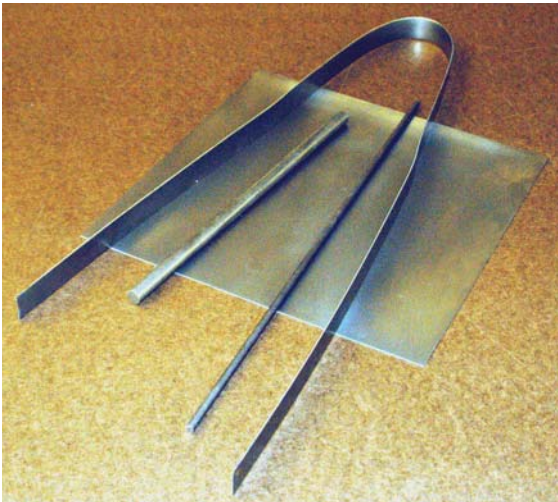

Mild steel shapes in the 2.007 kit

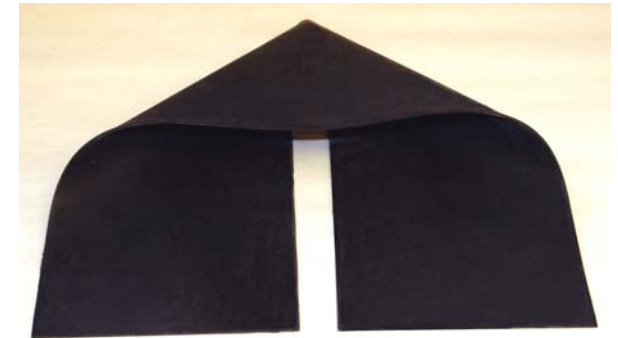

It's a bird! It's a plane! NO, look, it's a sheet of rubber from the 2.007 kit

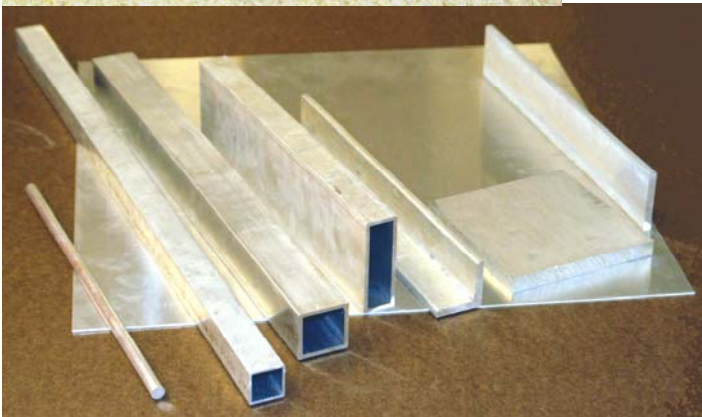

Aluminum shapes in the 2.007 kit



Plastic shapes in the 2.007 kit

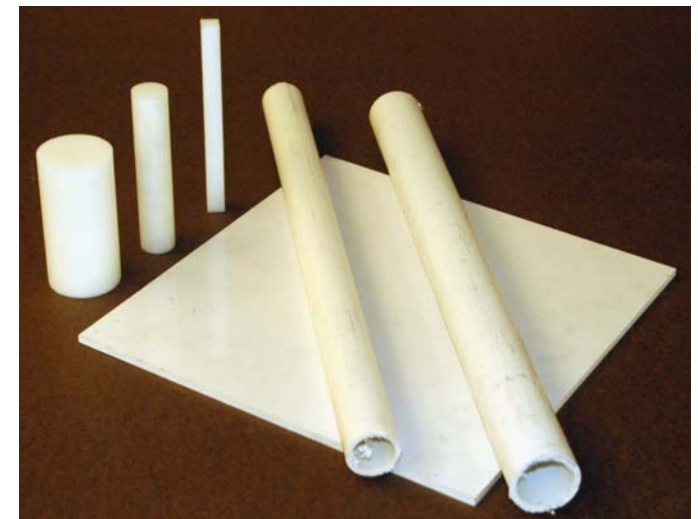

Materials: Wear, Strength & Stiffness¹

A material's strength is determined by a complex interaction of metallurgical properties, whereas wear resistance is a function of the type and distribution of particles on the surface of the part. For example, 7075-T6 aluminum has a yield strength of 462 MPa (67 ksi), almost twice that of A36 structural steel, yet in a wear test with the two rubbing against each other, the steel would win. In fact, *friction and wear properties of materials are highly dependant on which two materials are paired together, and the type of lubricant between them.* In general, dissimilar materials work best. For example, nylon on steel is better than nylon on nylon, and aluminum on aluminum is perhaps the worst! Often, wear-resistant materials have a hard carbide, nitride, or oxide layer on their surfaces. Hardened steels, ceramics, and thickly anodized aluminum all have good wear properties. Other materials, such as brass, cast iron, and most plastics, wear well when used in conjunction with a hard material because of the former's inherent ability to act as a bearing (its lubricity).

Table 1: Materials (C = cut, M = machine, W = weld, F = form, B = bond)

	Yield strength (MPa)	Modulus of Elasticity (GPa)	Density (g/cm ³)	Manufacturability
Mild steel	250	208	7.9	C,M,W,F,B
High strength Aluminum	275	69	2.7	C,M,W,F,B
White Pine wood	8	9	0.37	C,F,B
Birch	12	14	.66	M,B
Nylon (no fill)	40	2.7	1.14	C,M,W,F,B
Nylon (30% glass filled)	80	9.3	1.39	C,M,W,F,B
ABS (extruded)	20	2.0	1.05	C,M,W,F,B

Table 1 broadly compares various materials typically found in a robot design contest kit of materials. The web can of course provide much more detail, including various manufacturing methods. For example, the table

1. For a concise, yet expanded discussion, see A. Slocum *Precision Machine Design*, Society of Manufacturing Engineers, Dearborn, MI, pp. 330-340

shows that nylon can be welded (using ultrasonic welders), but not typically in a shop for a robot design course. All metals, with the exception of beryllium, have the interesting property that their specific moduli of elasticity, their modulus of elasticity divided by their density, are equal. Plastics, rubbers, and woods vary widely. Most materials exhibit some degree of ductility, where before they break, they start showing signs of yielding: Upon load release, but before the structure breaks, the structure will suffer some permanent deformation. In general, the stronger a material, the less it yields, and hence the less of a warning one has before it fails catastrophically.

The *Brinell B hardness* and the *Rockwell C hardness* (denoted by *HRC* and then the number) can be approximately related to the tensile strength of plain carbon and low-alloy steels by:²

$$\sigma_{MPa} \approx 3.45B \quad \sigma_{MPa} \approx 3.45 \left(\frac{1590}{122 - HRC} \right)^2$$

A common way to predict when failure will occur is to find an equivalent maximum shear or tensile stress in the part. Brittle materials have low ductility (e.g., ceramics) and usually fail when their maximum tensile or compressive stress is exceeded. Materials with higher ductility (e.g., most metals) usually fail when their maximum shear stress is exceeded. A complex state of stress can be equated to an equivalent stress using the *Mises yield criterion*:

$$\sigma_{yield} = \sqrt{\frac{(\sigma_x - \sigma_y)^2 + (\sigma_y - \sigma_z)^2 + (\sigma_z - \sigma_x)^2}{2} + 3\tau_{xy}^2 + 3\tau_{xz}^2 + 3\tau_{yz}^2}$$

$$\tau_{max\ metals} \approx \frac{\sigma_{yield}}{2}$$

Do you have components which may be subjected to high stresses? Try and predict the Mises stress and determine if the component will yield. Remember the stress concentration discussion from Chapter 5!

2. F. McClintock and A. Argon, *Mechanical Behavior of Materials*, Addison-Wesley Publishing Co., Reading, MA, 1966, p. 448.

Materials: *Wear, Strength & Stiffness*

- *Axial, torsion, and bending* loads can be applied to structures and components
 - An equivalent stress needs to be determined and compared to the material's yield stress
- Yielding in a component's material can mean the component has failed, as will the machine, or it can be used to form a component during manufacturing
 - Elastic instability (buckling) can affect shafts and columns in compression or torsion
 - Know your limits! (See pages 5-20 to 5-23!)

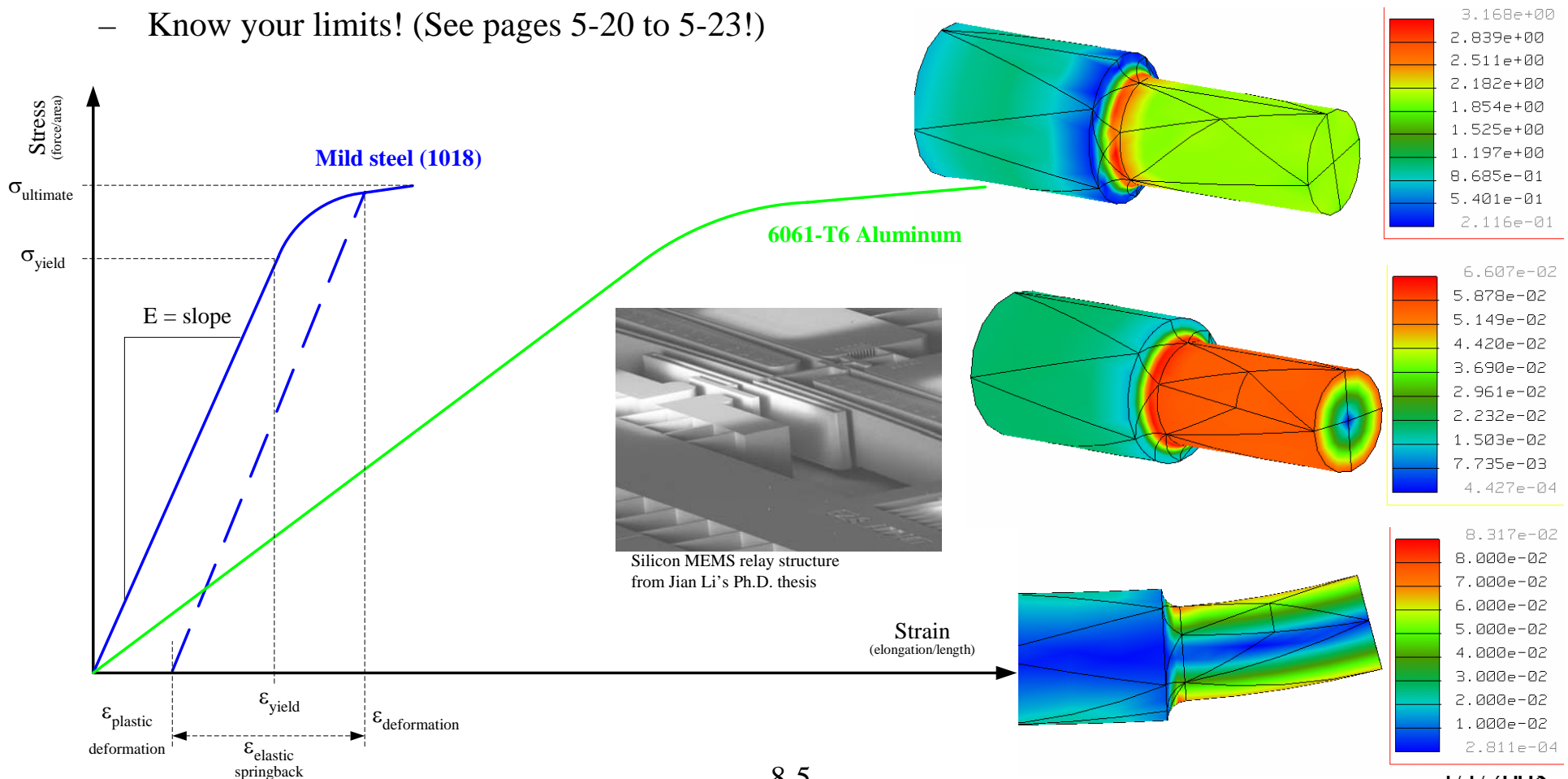

Visualization

A very powerful design technique for creating the structural framework for your machine is the ability to *play the movie of your machine or its modules working even though the machine does not yet physically exist and the design is still in the concept phase*. With your mind you should be able to imagine each component as it moves, and envision all the undesirable motions that might also occur. The structure must accommodate all these motions.

Once again, a bicycle makes a great practice device. Imagine riding your bike and squeezing the brakes. In your mind, see your hand displace the end of the brake handle so it pivots about a pin. See the other end of the brake handle move less, but hence with more force. See the cable being pulled by the brake lever. See the cable being pulled within the protective guidance sheath. Follow the brake cable along the frame, taking note of its attachment points and how motion of the handlebars does not cause the cable to shorten (else when you would turn, you would skid). See the cable connected to the linkage that holds the brake pads. As the cable pulls on the linkage, you should be able to see how it evenly displaces each brake pad to provide equal force to each side of the wheel. Your wheel is bent? See how the brake linkage floats about a central pivot point so even pressure is still applied to both sides of the wheel.

Now there is a hill coming up, and you have to change gears. Push the gear selection lever. How does it cause the derailleur cable tension to change? Is it a simple lever, or is it a ratchet where clicking one lever increases the gear ratio, and clicking another lever decreases the gear ratio. This allows your hand to remain firmly on the handlebar, so you could be shifting while riding a rugged mountain road. Can you see the detail of how this shifter works? In the early stages of a design, do you even need to know such detail for a module? Would it not be safe to assume that such a nifty shifting device could be developed by a dedicated focused effort. This might entail some risk, but a reasonable countermeasure would be to assume that you could always use a standard shifting technology to meet the shipping date.

Continuing, follow the cable to the derailleur. The force from the cable needs to pull the derailleur so it pulls laterally on the chain so as to guide the chain off of one sprocket and onto another. What is the optimum angle for the derailleur pivot axis? Does it matter at this point? Do you have the time to

optimize it now, or can you just leave an attachment point on the bicycle frame such that the derailleur can be bolted in place when it is optimized?

This is why being able to play the movie in your head is so valuable, for it serves as a last-minute check of your FRDPARRC table before you put details to the structure. It allows you to imagine your machine in action: It allows you to see if the design parameters are indeed capable of satisfying the functional requirements. As you play the movie, you are likely to discover details that you overlooked in the initial lofty conceptual design phase. You are also likely to discover impossibilities and very high risk FRs and DPs; on the other hand, you are also likely to visualize viable countermeasures.

As the number of functional requirements increases, your ability to visualize the entire machine will become more and more challenged. This is why having a FRDPARRC table is so important. It allows you to visualize one module at a time, and then after having visualized all the modules individually, you are more likely to be able to visualize the entire machine.

In addition to visualizing the overall kinematics of the machine, you can imagine fine details, such as when a trigger pin is pulled, will it jamb? In your mind, zoom in on the cross section of the mechanisms, and imagine the parts as they can rattle in the bearings that support them because of clearance. Slowly pull the trigger pin out. How will the forces be balanced? Will the pin suddenly rotate as it is no longer supported on both ends? Will this cause it to jamb in the hole in structure or in the component being triggered?

Furthermore, you can also visualize the effect of deformations on machine performance. One by one, imagine that each machine component were made of soft rubber, and visualize how it deforms under the loads imposed by the machine. This can help identify regions where extra design care must be used in the detail design phase.

You cannot be asked to turn in the movie that you have created in your head, but after playing the movie and carefully reviewing it, are there any design changes to be made? Visualize the machine sizing box for the contest. Now visualize all the motions your machine makes and the modules. Now try to visualize at least one overall structure that can achieve the functional requirements for your machine.

Visualization

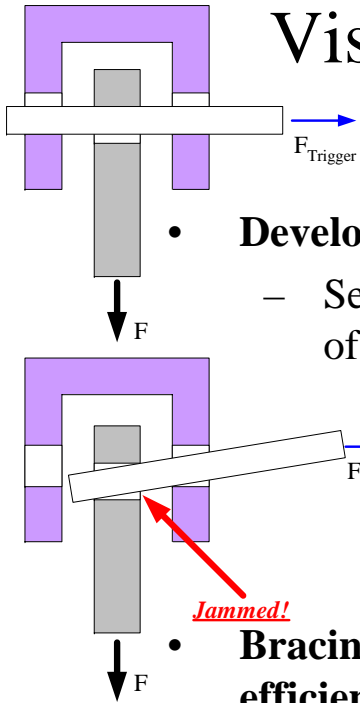

- **Develop your ability to imagine a structure deforming as loads are applied**
 - Sequentially imagine that each element of the design is a piece of rubber, while other elements are steel
 - Apply forces to the system and see how it deforms
 - Does the deformation cause problems?
 - How can structure be changed to minimize deformations?
 - *Play the movie in your mind*



- **Bracing elements with triangles (plate-type gussets or beam-type trusses) are the most efficient method for strengthening a structure**
- **Creating CAD or paper and pushpin models is an effective way to visualize a structure**

- Even if you are planning on using finite element analysis, a simple model can help you later determine if the results are meaningful!

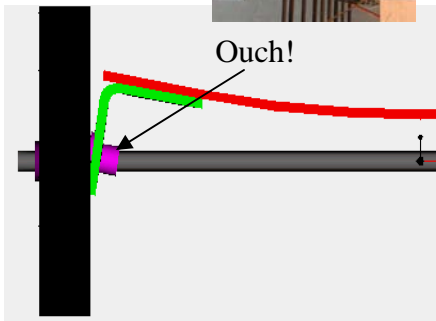
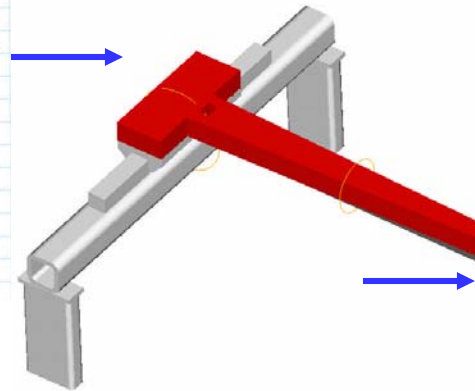
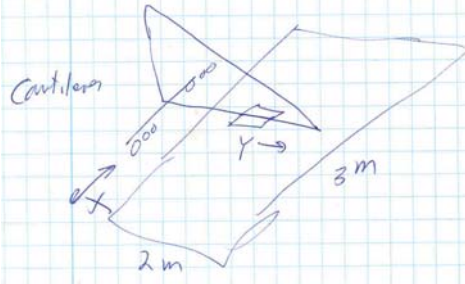

Layout: Introduction

Developing a strategy involves numerous rough sketches of stick figures and motion-indicating arrows. Concept development involves one-step finer resolution, but the sketches are still generally sketchy. However, once the final concept is selected and it is time to divide the machine up into modules, it is time for the layout. Layout occurs after you have completed the first-order design calculations to determine concept feasibility. Remember, analysis will continue during layout and especially during the detailed engineering phase which follows layout.

Layout is thus the design phase where the design engineer has sorted through numerous strategy and concept options, done preliminary calculations and/or experiments, and has a good picture in their head of what the design should look like including ideas for modules. The challenge is now to transfer thoughts into reality. Since all the machine's modules are attached to the overall machine structure, it is logical to start the development of the structure with a layout sketch for the machine to ensure that the structure will be designed with the attachment points and spaces needed for all the modules.

A layout sketch is thus a sketch that clearly shows the likely size of the modules and their relation to each other, with enough detail to show the overall design of each module. Later for each module, a more detailed layout sketch is also completed. For example, the layout sketch of a machine should show that an arm is articulating or extending (rotary or prismatic joints). It should also show the anticipated location of the drive motor and the type of connection to the arm. However, not so much detail should be shown that the designer feels constrained by too many preconceived details before the detailed engineering is completed.

A layout sketch often starts with the allowable outer boundary of the machine. Adding the general anticipated shape, size, and location of modules enables you to sketch different concepts for the machine's structure (frame). You may also want to sketch the location of the "tool" and the "work" (e.g., gripper and hockey pucks) as they are moved by the machine. Then you can place the modules and sketch the frame. You can then perform the appropriate analysis needed to size components. With your visualization skills, you can "see" how the machine will perform and check for any failure risks that may occur due to interferences between modules or structural deflections that could

cause elements to jam and fail. You could also start with a design sketch for the frame, and then add the modules, modifying the frame as you go. Which starting method is best? You should be able to see if a machine is to be structure dominated, like a crane, or module dominated, like a car, and then proceed accordingly. When to move from a hand sketch to a solid model depends on the skill and comfort level of the designer, but it ultimately should happen.

How can you ensure that you have just enough detail, but not too much? Use your FRDPARRC tables from Strategy, to Concept, to Modules, to understand what functions the structure must perform. Remember, the FRDPARRC tables provide a means to organize your thoughts with words and simple sketches that described your ideas. FRDPARRC tables are roadmaps to help create a first-order sketch of the machine. They make sure there are some features on the layout sketch that are associated with each of the design parameters you have identified for your "best design".

Too much detail in the layout phase is a waste of time, because after the layout phase comes the detailed engineering phase, and this almost always leads to changes in the modules, their relation to each other, and in the overall machine. Design is an iterative process, and any design process must itself be flexible and minimally burdensome to the creative design engineer. How can you develop your layout skills? Like anything else, practice, practice, practice. It never stops, it just keeps getting better!

In order to develop your layout skills, start with something simple, like your bicycle. Draw the major components, the wheels, the gears, the derailleur, the pedals, the brakes, the handlebars, the seat. Next draw simple lines to connect these components. Did you draw the lines along the lines of a conventional frame? What other collections of lines might also achieve the same function but with a different topology? Layout is a great catalyst for thinking of configurations you might not have thought of before.

Next, layout a simple 2WD car upon which your robot might be built. How would a 4WD car look? How about a car with two large drive wheels in the middle, and then swivel casters at the front and back? Is there a risk of hang-up in the middle? What might be a countermeasure? With these three base-platforms, see how you would add your modules, such as an arm or a bulldozer, or maybe another bother-bot.

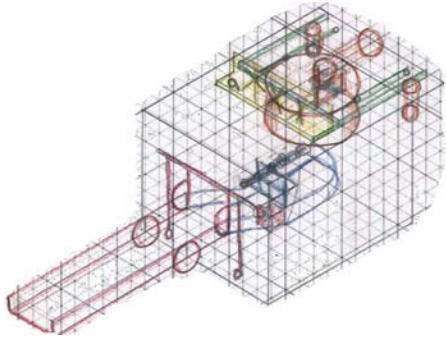

Layout: *Introduction*

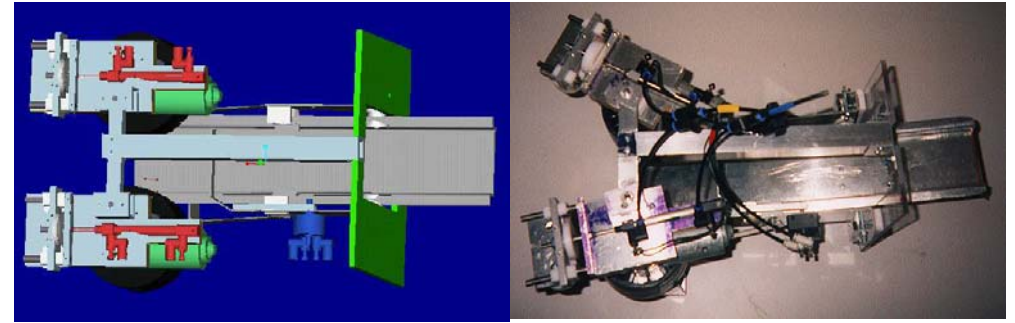

- **Layout** is used to initially define relative placement of elements and the supporting structure:
 - The **Layout** is the first embodiment of the *design intent* and defines boundaries on the structure
 - *You can create several simple stick-figure layout sketches of different concepts*
 - *Use appropriate analysis (e.g., 1st order error budget) guided by the layouts to help select the best!*
- A **Layout Drawing** is the graphical interpretation of the FRDPARRC table's Design Parameters:
 - As a design progresses from **Strategy**, to **Concept**, to **Modules**, to **Components**, the *layout* is the first step towards creating the details
- A **sketch & notes** can suffice for an initial layout, & serve as a road map for creating a solid model
- A **solid model** can serve as a layout, as long as one takes care to not add a lot of detail:
 - Use datum planes and curves referenced to a global coordinate system
 - Beware of referencing features to other features which may later be moved or deleted

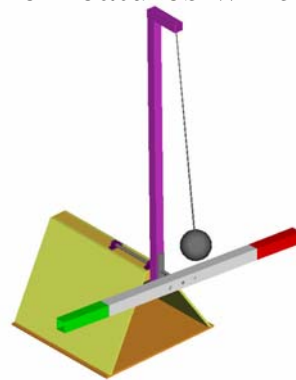
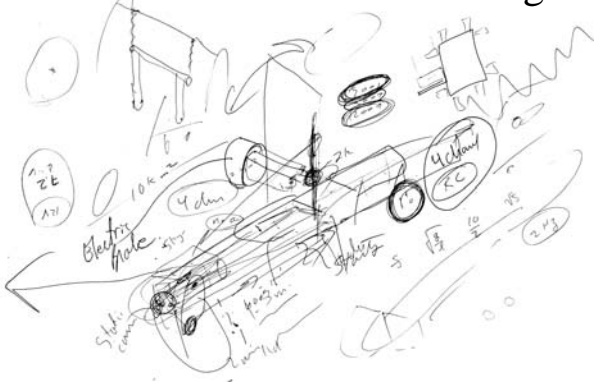

Layout: *Sketches*

Since most machines must have an overall structure to which modules are attached, a skeleton or frame may be the first module whose layout is sketched, or as mentioned previously, the modules can be sketched in their relative positions, and then the structure can be added. As an example, consider the layout sketch for Alex Sprunt's wall-crawler. It shows sketches of the modules as they are initially envisioned, and their relative locations in order to enable them to execute their function: The machine crawls along the wall of 1998's *Balcano* contest to position the machine. The grey "tongue" then extends to form a trough to channel the balls towards the scoring bin. With the modules sketched in the desired position, the structure can then be sketched to which the modules will be attached. For this design, how might you start with a sketch of the structure and then attach the modules? Which method do you think would enable/help you to better develop the modules?

When there are strict physical size limits, it is helpful to sketch them and then sketch within those boundaries. Once simple "stick figure" lines are drawn within the boundary to show the intended structural loop (see page 3-24), arrows should be added to show applied forces, moments, and motions of the "tool" and the "work" (e.g., a lifting bucket and the balls). Next, in order to evolve the stick-figure that merely connects the modules into a layout sketch for the structure, **FUNdaMENTAL** principles can be applied (see Chapter 3). For example, remember to form triangles to brace structures and achieve a high-degree of stiffness; and apply the parallel axis theorem. Do not just add thickness without carefully thinking! This will result in a first-order estimate of what the structural detail might look like. Appropriate analysis can be applied to initially size members and determine feasibility. With each step, more and more detail is added. With each step, the risks can be assessed and countermeasures taken if the design appears to becoming too complex or the risk of success too great.

In order to take the next step, which would be creation of the solid model, the layout either has to be neat and accurately show relative sizes of elements, or it has to be labeled with intended dimensions. The *Tiltulator* contest table evolved from an early sketch and the PREP process as shown in the first sketch at the top of the page. From this tangle was extracted the layout sketch, which shows notes and dimensions necessary for the design engineer to then develop the solid model of the system. Note that once the solid model

was developed, 3D and 2D views were easily created which were helpful in the development of contest machine layouts.

It is important to be able to visualize the environment in which your machine must function. This can be aided by making photocopies of a layout sketch of the environment which will allow you to sketch and compare different layouts of your machine. You can then literally wallpaper (temporarily) these around your working or living space, so that while doing other things, you can be subliminally analyzing and evolving your design.¹

Sketch the layout of the contest table and as you do so, try to envision yourself as a machine driving around on it. What are the regions which might cause you to get stuck? Are you still happy with your concept? Now is the time to change it before launching into your machine's layout phase.

Gather your most recent FRDPARRC tables for your strategy, concept, and modules, and decide if you want to start with the structure. If so, then sketch in modules. If you want to start with the modules, lay them out, and then sketch in lines that join the modules. With good guesstimates of the forces on the modules, add thickness to the lines of the structure, such that it will then have sufficient stiffness or strength. Add notes and major dimensions to the layout drawing to enable you to create the solid model of the machine. Remember, solid models will be made of parts and subassemblies that will then be brought together to create a full solid model of the machine.

If you run into problems with making things fit and have to change your design, update your FRDPARRC tables accordingly; however, minimize busy paperwork. Your goal at this stage is to iterate and converge rapidly, yet maintain enough documentation to enable others (or yourself at a later date) to follow your thought process.

1. Another social opportunity: ask that potentially special someone if they would like to help you wallpaper your room... and then while they are helping hang sketches, you can ask them what they think of your design!

Layout: *Sketches*

- Use *Motion diagrams* and *stick figures* to help define and select your concept as initial starting points for your layout
 - Design is like a flexible anagram
 - You are allowed not only to rearrange things
 - You are allowed to add or subtract things!
 - Use your knowledge of the FRs and DPs and of fundamental principles to catalyze the creation of the layout
 - E.g., the red-line-strategy machine grabs the pendulum with a flexible arm and then goes to the end of the beam
 - What kinds of structures can enable a machine to do this?
 - ***In order to define the structure, you will also have to sketch some basic ideas for the mechanism***

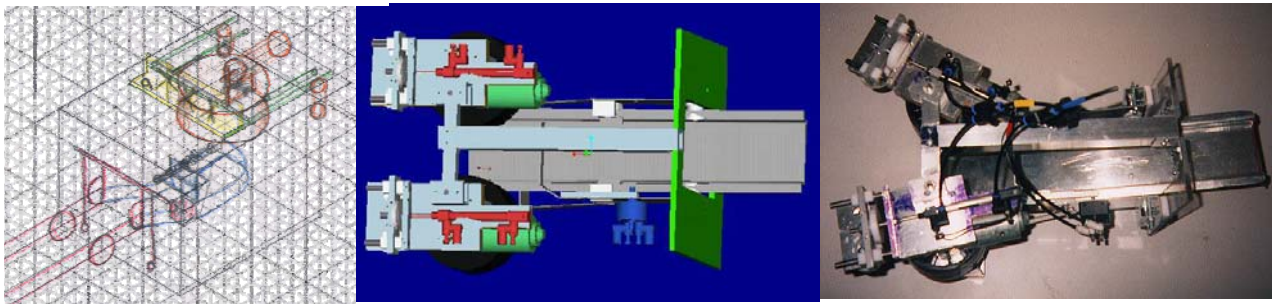
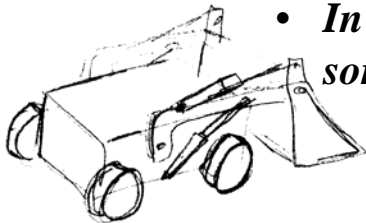

Alex Sprunt's Wall-Crawler

1) Early concept development (used in PREP)



2) Layout sketch (used to create simple 2D CAD drawing or solid model)

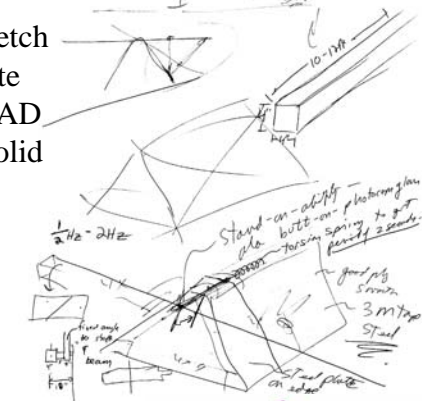

3) Solid model (and generated end view)

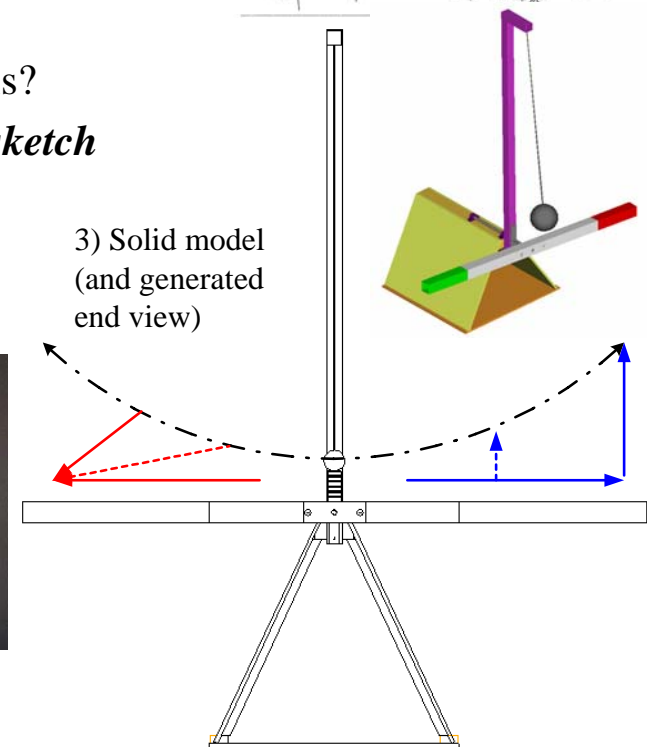

Layout: *FRDPARRC*

To help review the design process and hardwire it into your neurons, close your eyes and review the various topics discussed on the last three pages. Now scan through your FRDPARRC sheets to make sure you have a clear view of what you want to accomplish. Systematically go through your design, as documented by the FRDPARRC sheets, and apply Maudslay's maxims:¹

- Get a clear notion of what you desire to accomplish, then you will probably get it
- Keep a sharp look-out upon your materials: get rid of every pound of material you can do without. Put yourself to the question, 'What business has it there?'
- Avoid complexities and make everything as simple as possible
- Remember the get-ability of parts

Now, crank up the stereo and prepare to sketch your layout drawing:

A good song to play would be from the Rolling Stones:²

- "You can't always get what you want.
- But if you try sometimes well you might find
- You get what you need"

Now use your FRDPARRC sheets to guide creation of a layout sketch for the machine. Make sure to keep copies of the FRDPARRC sheets in front of you as you sketch (you can tape them up around your work area like wallpaper!):

Sketch the overall *functional requirements* of the machine by the actions it is to take. Since you probably already have earlier sketches of the stick figure with arrows indicating motions and forces, you are basically already done with this step. Keep a copy of this sketch in front of you as you begin the layout sketch for the actual machine configuration.

Using the stick figure for your machine as a *skeleton, foundation, or platform* for your machine, sketch objects for each *design parameter* with just enough detail to indicate the type of mechanism you intend to develop in detail (later on). You should have done preliminary design calculations in the concept feasibility stage, but you may find that more *analysis* is now required as you begin to put actual geometric bounds on the design. If you need guidance on what a module might look like or how much space it might take up, look at other machines from the past as *references*.

The layout phase is also the last-chance to consider different *risks* that your machine will encounter. How confident are you of the physics of operation of the module whose boundaries you are sketching? As you are sketching its boundaries, you will have to be thinking about its detail. If you find your mind a blank as to what detail may actually go into the box you are sketching to define the module, then you should label it as being a very (perhaps the most) critical module. You should be able to say to yourself "I am not sure how I will do this, but I can envision several different ways..." in order to make the risk manageable.

Finally, as you are sketching and making note of the level of risk for each module, you can also be thinking of countermeasures ranging from "I can just delete the module and if needed add a simple weight to maintain machine balance" to "If this module does not work, in the same space I can replace it with a simple dandlewidget to achieve some effect".

The layout phase will often leave you with more questions than when you started. This is good, because it has served its purpose of helping to define the detail that will be required in order to create solid models of your machine. From the solid models you can make the manufacturing drawings, from which you can then make the parts and the machine.

Before you complete the layout sketches for your machine, make sure you have scanned through the rest of this book to activate your neurons with design images that can be useful when you start the layout sketches for your own machine.

1. Review them if needed on page 1-4.

2. Mick Jagger & Keith Richards 1969 <http://lyrics.all-lyrics.net/r/rollingstones/letitbleed.txt>

Layout: *FRDPARRC*

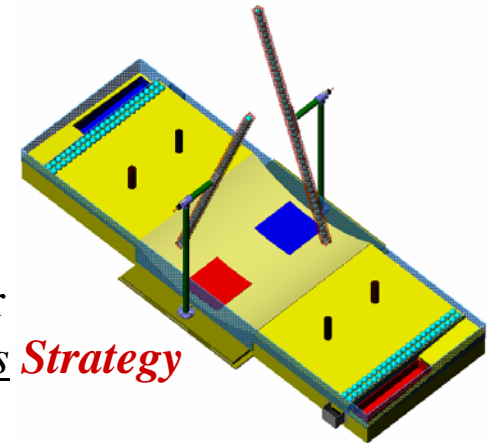

- Use a FRDPARRC table to guide creation of initial layout sketches
 - Example: For the *MIT & the Pendulum* contest, create layouts for *Concepts* for *Start pendulum swinging and collect balls and pucks* *Strategy*

Functional Requirements	Possible Design Parameters (Modules FR's)	Analysis	References	Risk	Counter-measures
Gather pucks and balls and deposit in goal	1) Pick up and score one at a time 2) Harvest lots and dump loads	1) Time/Motion study, Friction/slip, Linkage design 2) Friction, slip, linkage design	Physics text and past contests. Farm equipment websites	1) Not enough time to make multiple trips 2) Gather bin is too large	1) Gather 2 or 3 objects 2) Gather 2 or 3 objects
Actuate pendulum from ground	1) Vehicle knocks pendulum as it drives by 2) Fixed-to-ground spinning actuator	?	?	?	?
Block opponent	1) Botherbot 2) Pendulum clamp 3) Cover goal	?	?	?	?

Layout: "GeekPlow" Example

Let us explore how layout sketches can evolve. Sketch (1) is a simple side-view layout sketch for the *Start pendulum swinging and collect balls and pucks strategy*. Sketch (2) shows a layout sketch for a car *concept*, which evolved in parallel with playing with the spreadsheet on Page 7-17. Two motors would have enough power, but wheel slippage could occur, so 4 wheel-drive was chosen. Past experience showed connecting the front and back wheels on each side of the vehicle is difficult to do simply, and thus to ensure high efficiency and minimal complexity of the car, four motors would be used. However, they can be wired in two sets of two, so two control channels would still be left. With four motors driving, there should be no shortage of power, and enough vehicle speed could be obtained to enable the car to ram the balls and send them flying over the lip of the table into the scoring bin. In addition, the ramp could perhaps ram the puck stacks and make them fall onto the upper part of the ramp, and then they could fall into the scoring bin.

Sketch (3) is a layout of the gearmotor/wheel *most-critical-module*. Note that as sketched in (2) two sets, mirror images, would have to be made. Is this bad? Should 4 identical units be made instead? What is the level of *granularity* of the elements in these modules? Fine granularity means that most of the elements are identical, only the baseplate onto which the units were assembled would be mirror images.

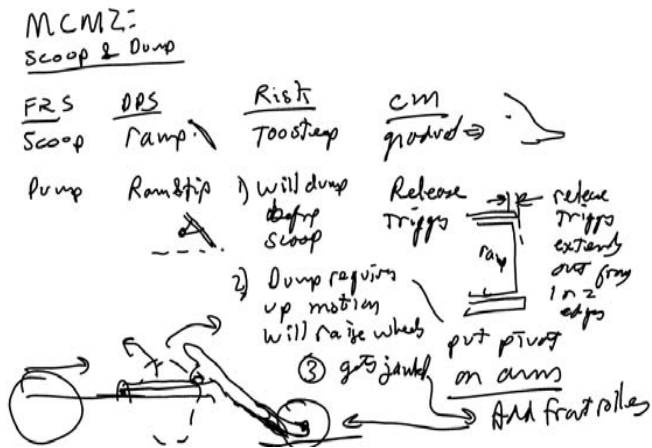

What is the next most important module? Probably the plow because it could be just a simple static plow, a default countermeasure, or perhaps a more sophisticated unit as sketched. Making note of the FRDPARRC chart entries and then sketching a correlated element helps the idea to evolve: Words trigger images, and the images highlight risks...and henceforth catalyzes invention. From this coarse layout sketch evolves more detail, where the next step would be to use solid modelling to further explore the geometry, or in some cases, analysis comes first. Before final commitment, a bench level experiment or bench-level prototype of this mechanism can be built and tested.

The result is a two-stage ramp/plow system shown in the sketch below. The rear link pivots and prevents the plow from raising the front of the vehicle as it collides with a rigid object. However, to prevent premature dumping, a trigger is used which must first impact the wall...

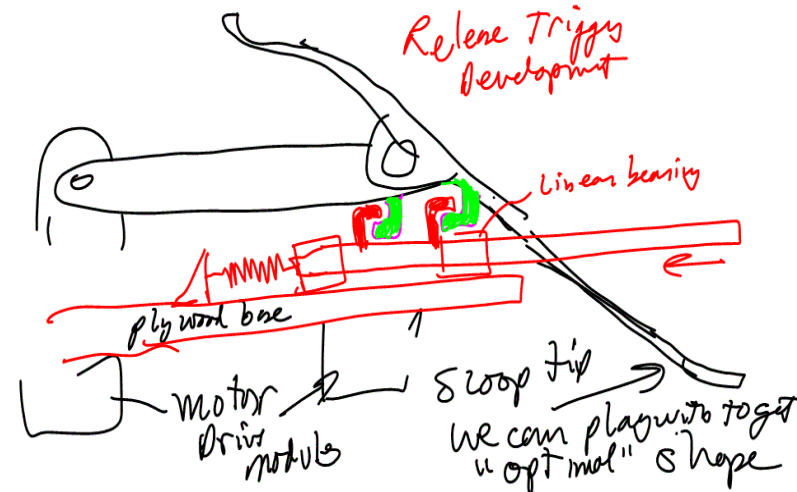

Sketch (4) brings it all together to show how countermeasures/design solutions evolved with risk identification: Just the way environmental pressures can cause a species to evolve, potential risks cause a design to evolve. This is the essence of the iterative process that is design.

Have you created a similar set of evolutionary sketches for your machine yet? Now would be a good time to start!

Layout: Analysis & Bench Level Experiments

An initial layout drawing can be as simple as a stick figure, or a stick figure with some guesstimates of component and structure size. Since they can be created quickly, they can be used in the initial concept selection process if they are coupled with appropriate analysis. In fact, the process can be:

1. Create *initial layout sketches* of most viable concepts initially selected from a first-round application of weighted concept selection charts (see page 2-25). Often a more detailed sketch model is also created to help the designer visualize the system (see Page 2-7).
2. Apply the *appropriate level of initial analysis or experimentation* to determine feasibility. For example, a *First Order Structural Analysis* should be conducted to ensure that the proposed frame is stiff or strong enough to handle the anticipated loads. A *First Order Error Analysis* is used to identify the sensitive directions and estimate the dominant Abbe or sine errors. If these errors are about 1/4 or less of the total allowable inaccuracy (error) in the system, the design probably could be engineered successfully in the detail phase. A *First Order Power Budget* is critical to the motor and energy storage system selection process.
3. Sketch the *final concept* to the next level of detail by initially sizing structural members and bearings using strength or stiffness criteria according to the type of machine you are designing. Where accuracy is required, create a detailed *error budget* (see Topic 12).
4. Create and check the *power budget* to ensure there is enough power and energy to accomplish the desired task. This also allows you to determine the load power rate, and then you can initially select a motor whose power rate is at least 4 times the load power rate. Then you can compute the optimal power transmission ratio and determine the size of the motor and gearbox and then complete the layout drawing (see Topic 7, page 7-26).

There will be times when the cost (time) to do analysis is too high. Sometimes a simple analytical model can be used for a first order estimate of performance, and then a *Bench-Level Experiment* (see page 2-8) is designed and conducted for less cost than it would take to perform a more rigorous analysis. However, a BLE does not allow you to play “what if?” games with the variables, unless the experiment was designed as such to test many parameters.

When creating robots for design contests, after first order calculations are done, a BLE is often the most appropriate analysis tool. As an example, consider the structural platform for the *GeekPlow* car sketched earlier which will be very stiff, and thus nominally, only three wheels at a time will ever touch the ground. Will this make the vehicle difficult to steer? Will this provide enough traction? What are the options and their complexity? An analytical determination of these questions would be very costly in this application. On the other hand, a sketch model could easily be built and tested. If the *risks* were determined to be significant, they could be *mitigated* without too much effort in the layout stage. If one waits until after the car was built and tested, and then the design is found to have problems, one would be in serious trouble. Two *countermeasures* that can be considered are: add a suspension to at least two of the wheel modules (see page 5-16), or add an articulation between the front and rear halves of the vehicle. The sketch shows how the same bearing blocks and shafts that are intended to be used for the wheels can also be used to make the rotary motion joint between the front and rear halves of the car.

Consider the finite element analysis (FEA) results for the waterjet cutter main axes shown, where the concept was to use a single large linear bearing for each of the machine’s axes. Since the machine is small compared to its big brothers, which used two bearing rails per axes, preliminary analysis indicated one bearing rail per axis should be fine. The FEA with some first-order joint property assumptions then showed that the machine had great promise in terms of its structural resonance being high enough to allow it to be controlled with good accuracy. However, because it was difficult to create accurate FEA models of structural joints, before committing to the expense of a prototype machine, a simple BLE of the bearings and structure were conducted. The experiment showed that the design could work, but it also illustrated the difficulty in obtaining the components, and this led to a slightly modified approach, but the general concept remained the same.

Although analytical or philosophical insight is the motivation for a new concept, unless you have the experience, or the analysis to justify every major design decision, you will need to do experiments. Hence when creating a layout for a machine, never be shy about verifying a model or answering a question of determinism. Remember, simple formulas, spreadsheets, and Bench Level Experiments and Prototypes are powerful tools. What first order analysis and bench level experiments are you planning?!

Layout: *Analysis & Bench Level Experiments*

- Since layout involves creating the overall skeleton or supporting structure, it also is a first chance to define the overall structural performance
 - The key is to understand how the *structural loop* behaves
 - Sequentially imagine each component is made of a soft material...visualize...
 - Estimate deflections, stresses, and vibration modes
 - Perform first order calculations to size members and components
 - If the machine is complex, Finite Element Analysis (FEA) may also be used
 - If analysis is too costly (e.g., time to do), consider a *Bench Level Experiment*

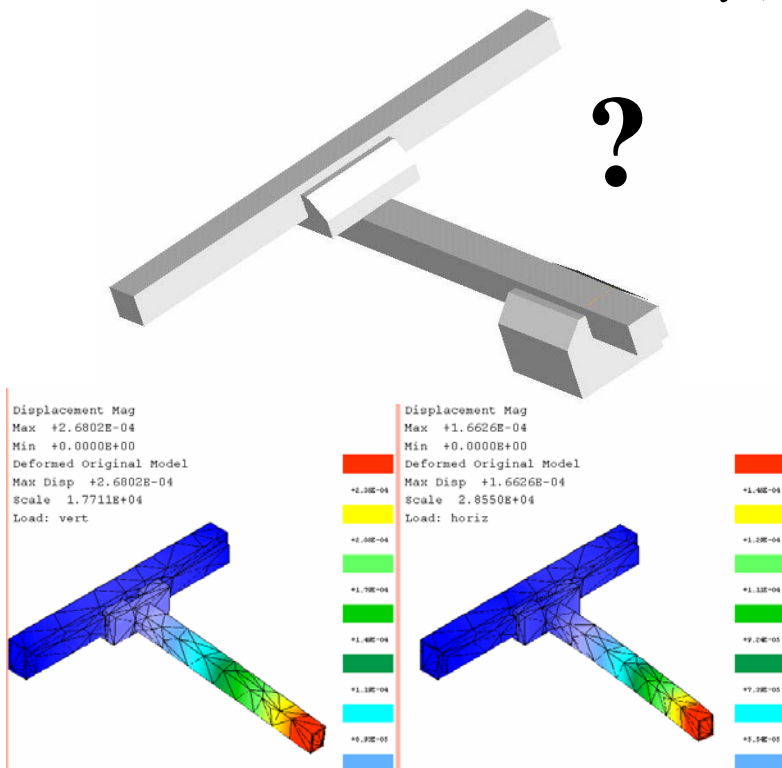

Displacement Mag
Deformed Original Model
Max Disp +1.0000E+00
Scale 4.8469E+00
Mode 1, +3.4137E+01

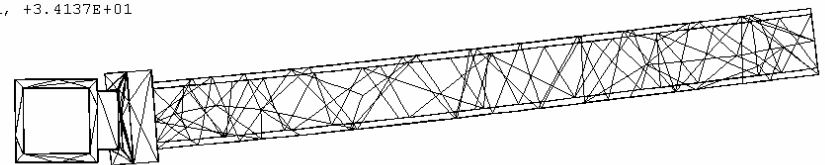

Layout: *Evolution & Comparison*

Every design changes as it evolves from the initial stick-figure concept sketch to the more detailed layout drawing. At every step of the way the FRDPARRC charts should motivate analysis and comparison. The comparison process itself highlights which attributes of which designs are best. The design engineer should then determine if these best attributes can help the “best” design to evolve to include them.

For example, is the *GeekPlow* design the best design for winning the *Schwing!* (*MIT & the pendulum*) contest? What if you develop this idea and learn that an opponent is developing a fast machine to race across the table and plant a screw-jack that cranks down on the bin, which is what Martin Jonikas did to win. In a robot design course, and often so in life, you should keep on track to produce a well-designed reliable machine that works in the manner in which it was engineered. AND THEN you should think about a blocking (marketing, sales & service) strategy to deploy... Then, practice, practice, practice, so when the contest time comes, you can drive so fast and so well, that you can confound any opponent and still win. In fact, Martin won every round easily, but in the final round, his opponent almost successfully blocked him with a “normal” machine!

How different is this from real life? Should you not abandon what you were doing and rush to copy? NO, because you will always be behind who you are copying and will not do as good a job. It is far better to release a robust reliable product with many good attributes. This allows you to establish market presence and a reputation for reliability (if you are a student, this then means you can earn a good grade and have a well-engineered and built machine for your portfolio when you go job hunting!). Then you will have time to evolve your design. For example, if you develop the fast car and a reasonable plow, do you have time for a bothering module, or maybe your new jack scoring module?

Since layout drawings are by definition simple and fast, when you have two seemingly equally viable concepts, you can use layout sketches and preliminary analysis to help decide which design is best. In fact, it is probably true that ALL designs evolve beginning from the time they are first sketched; however, this can only occur if you make sure to leave your ego in a box at home. With an open mind you will often come to a design review with a nice

drawing of the machine or your part of it all laid out nicely. If it is the concept selection phase, a weighted concept selection chart (see page 2-27) can be used to help select the “best” design. However, other concepts will usually have some better attributes, and then the layout sketch of the “best” design can be quickly modified. For example, the *GeekPlow* car body can have a line drawn through it and bearing blocks and a shaft added to enable its main frame to twist and hence ensure that all four wheels are always in contact with the ground. This will increase traction and steering control.

Best designs that are chosen purely on the basis of qualitative selection charts and committee deliberations are gambling with the future of the project. Final concept selection decisions MUST be supported by physics, either via analysis or Bench-Level-Experiments!

Returning to the waterjet machining center design example, two more FEA results are shown. Previously, the FEA results showed static deflections. This time wireframe images are used to show the animated motion output from FEA dynamic simulations. This lets the engineer see how the structure will behave dynamically, and where bending vibrations will occur. Often, dynamic deflections that occur at resonant frequencies are not in the same location or direction as the static deflections. This is particularly true for higher-order modes of vibration.

Consider a simply supported beam loaded at its center. The static deflection causes the beam to bend in a simple curved-shape that can be described by a radius of curvature, and this is also the first mode of vibration. However, the second mode of vibration causes the beam to bend into a sideways “S” shape. Higher modes add more nodes. In more complex structures, these nodes can occur in undesirable places in the system. A classic example is when engine vibration in a car causes a body panel somewhere else on the vehicle to rattle and drive the driver crazy... Advanced analysis can be a part of the layout process for complex machines.

Review your design selection charts and make sure that a good attribute has not been overlooked that might be added without too much pain. Is there some BLE or analysis that still needs to be done, which if the results are surprising might cause you to take appropriate countermeasures?

Layout: *Evolution & Comparison*

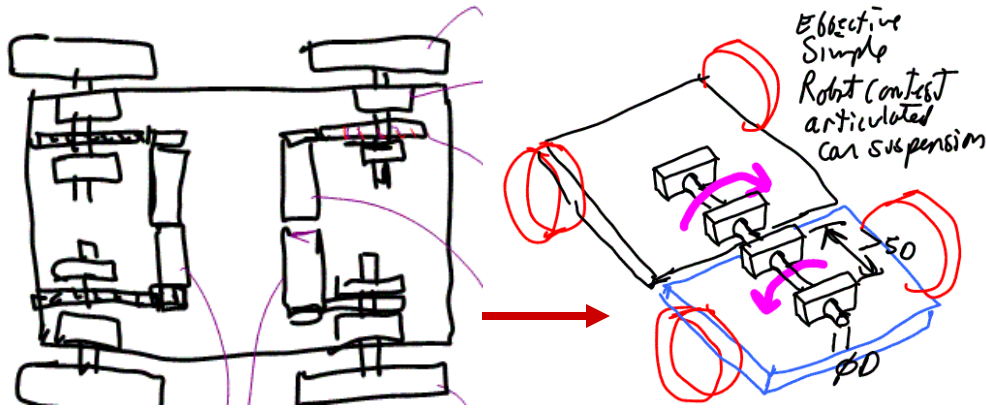

- There are often two or more possible design paths
 - Use analysis, manufacturability, & robustness design reviews
- The overall structure must be defined before module development can commence in earnest
 - Make the design amenable to evolution as detail later emerges
- Use weighted design comparison charts

Comparison between one large or two small bearings		
LWH55 (T2 preload)		
Moment (kgf-m)	42	
Deflection (rad, minutes)	0.000582	2
Moment stiffness (kgf-m/rad)	71,463	
distance to load (m)	0.12	
Load (kgf)	100	
resulting moment (kgf-m)	12	
resulting deflection (rad)	0.000168	
resulting deflection (microns)	20.2	
equivalent stiffness (N/micron, lbs/inch)	49	286,086
rated moment load capacity (kgf-m)	431	
equivalent load capacity at outside edge (kgf)	3,592	
Lwhd15 (T2 preload)		
Force (kgf)	200	
deflection (microns)	10	
Lateral stiffness	20	
distance between bearing rails	0.2	
stiffness (kgf-m/rad)	800,000	
rated load at edge of table (2 trucks) (kgf)	1900	

Displacement Mag
Deformed Original Model
Max Disp +1.0000E+00
Scale 4.6500E+00
Mode 1, +2.7290E+01

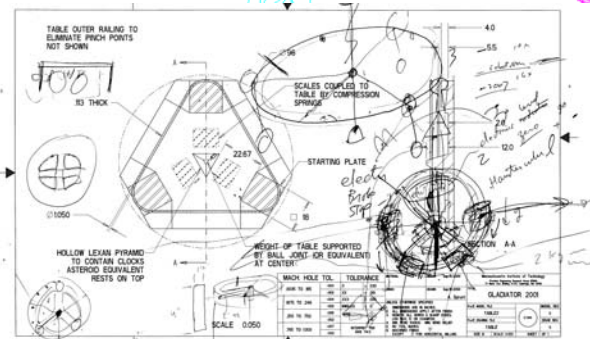
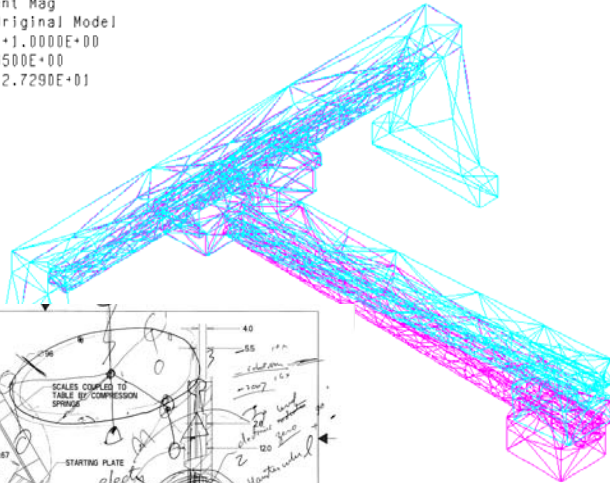

Displacement Mag
Deformed Original Model
Max Disp +1.0000E+00
Scale 4.0000E+00
Mode 1, +3.0250E+01

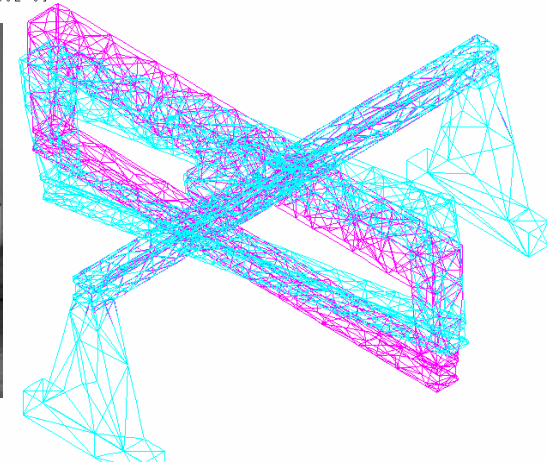

Layout: *Solid Models*

Layout sketches can be considered as the time when you are still free to think wild and crazy and randomly; after all, pieces of paper with sketched pencil lines can be turned over and a new page started with almost no effort. Solid models, on the other hand, generally take more effort and designers are less likely to discard them. This potentially starts them climbing up the cost curve with less and less increase in performance. This is where many design engineers get into trouble: They create a quick solid model for the purposes of laying out a design, and because they anticipate having to redo it anyway, they do not take as much care as they should in defining their *design intent*. BUT they then end up with a concept they solid modeled which has poorly defined design intent. Sadly, they rarely take the time to properly create the model.

Design intent is the overall philosophy that will govern the design. For example, the design intent of a machine tool is to make accurate parts; therefore, the machine itself must be extremely accurate. It must be designed and manufactured with respect to certain reference planes and features that are not to be messed with. The design intent sets the tone for how features will be referenced. For example, all features should be referenced to datum planes, so that any feature ideally should be deletable without causing the model to crash.

Problems can occur when a solid model is used to layout a design and care is not taken to dimension features with respect to unchanging, or very well solidified and monitored global references. During layout, if the design engineer is not thinking to the future, features may be dimensioned or referenced to other features in order to rapidly create the model. However, some features will likely be deleted as the design evolves, with the result that the model can crash. Creating a robust solid model means following a robust process.

Another way to build a robust solid model layout is to build up components from simple shapes. For example, a shaft with many features should not be created in the layout phase by drawing the entire complex cross section and then revolving it. What if some of the features are not needed? One cannot simply set the dimensions to zero because most modelers set a minimum feature size. In addition, it would clutter the model with extra dimensions. It is far better to create a basic cylinder, and add features as individual cuts as the design progresses. If each cut is referenced to a datum, then any one cut can be easily deleted.

The sequence of solid model layout drawings for the waterjet cutter shows how layout solid models can be effectively used to test different ways the concept of using a single bearing rail can be realized in order to create a low cost small-size abrasive waterjet machining center (the OMAX 2626).

In fact, there are two general approaches for creating a solid model that can be used during layout, and that will also have a greater likelihood of being able to be used later for the detailed design phase. The first approach is to define potential modules essentially as blocks, or very coarse structures. These “boxes” or coarse structures have reference points or features which define where they will connect to other modules or to the structure. Each module can then be developed in detail, but it must be able to “fit in the box”. As long as the reference features are maintained with respect to the boxes, than what goes in the boxes can evolve with relative freedom.

The second approach is to create a *skeleton structure* from reference lines, arcs, and planes, which is essentially a stick figure that depicts the minimum point-to-point geometry of the machine. Reference points on the skeleton structure are where modules would be attached. Structural members of size determined by appropriate analysis are then assembled to the skeleton structure as they are developed. Since elements are assembled to the skeleton structure, any single element can be deleted without causing the model to crash. When the design is finalized, relations between dimensions and features of individual parts can then be created.

Rony Kubat’s solid model is shown along with the final machine he built for the MechEverest competition. Rony finished in the top 4, and his robot was the best engineered and the best detailed. His attention to detail, including sending out his aluminum parts to be anodized, was amazing, and the parts were made from drawings generated by the solid modeler. Note how he created a model of the sizing box and checked to see that the solid model of his machine would fit inside the solid model of the sizing box.

Use your hand-sketched layout to create a solid model based layout drawing for your machine. Which of the two above methods do you prefer? Your model should help you verify that the space you have allocated for each module is sufficient, and that you can create a sufficiently strong and stiff structure to meet your design’s functional requirements.

Layout: *Solid Models*

- In order to create an appropriate level-of-detail solid model layout drawing:

- Use the FRDPARRC tables from **Strategy**, to **Concept**, to **Modules**, to **Components** to understand what functions the structure must perform

- The chicken-and-egg issue is that no detail yet exists, only sketches and spreadsheets

- Most machines must have an overall structure, a skeleton or frame, to which modules are attached

- » Creating the skeleton or frame is the critical first step in catalyzing the generation of detail for all the modules
- » Details are added as the design progresses

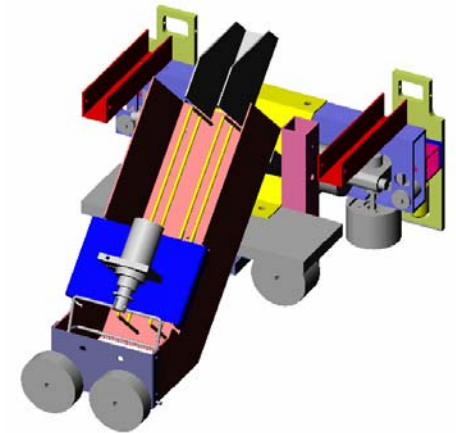
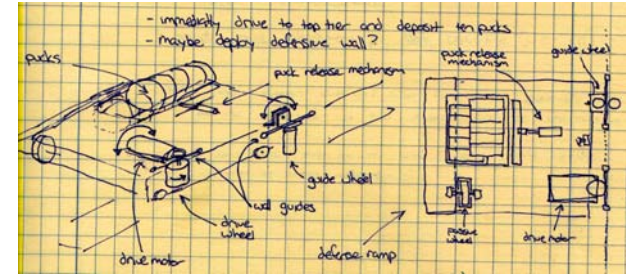
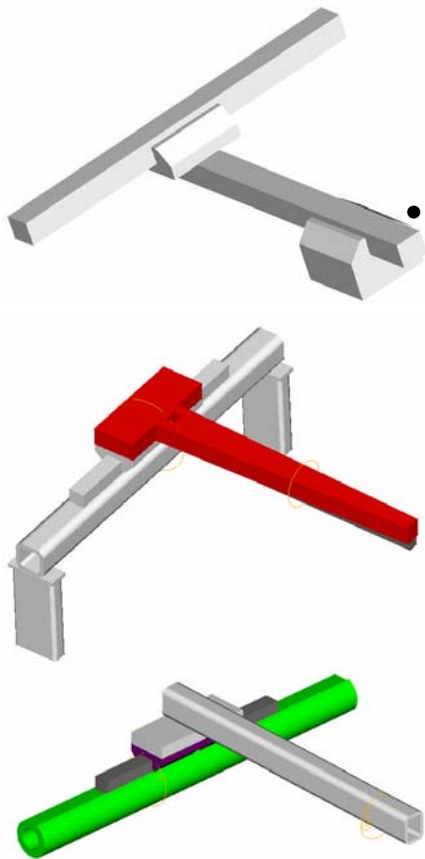

Rony Kubat's rough sketch, solid model and machine. Rony's solid model fit in a solid model size-constraint box as did his real machine in the real box. It performed as modeled and very nearly won the 2.007 *MechEverest* contest as it scored a perfect 50 points EVERY time...

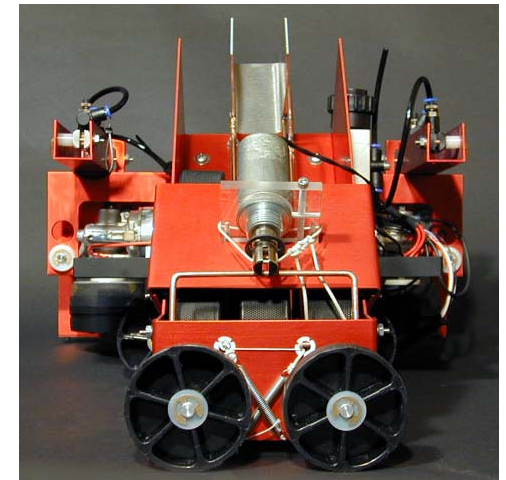

Stability

In the context of a robot for a design contest, there are several forms of structural stability to be considered. *Elastic stability* is the ability of a structure to bear a load and then elastically return to its unloaded shape; however, if the load increases beyond a certain point, the structure may suddenly undergo a rapid increase in deflection that quickly leads to material failure. Although there are cases where buckling can occur without exceeding the material yield strength (see page 4-26)¹. In machines, common static loadings include axial and torsion loads, both of which can reach a point where the structure suddenly buckles. On the other hand, *Dynamic stability* is the ability of a structure to not become so excited by a periodic force that it shakes itself apart. When the frequency, or an integer multiple thereof, of an applied dynamic force is equal to a natural frequency of a structure, the loading self-reinforces and it can cause the structure or component to become overloaded and fail. Only with good damping, energy lost per cycle, can this effect be prevented. Dynamic stability is discussed in greater detail on page 5-26

Axial Loading: Take a long thin rod and place it lengthwise between your hands and push on it. There comes a time when it suddenly bends sideways a lot. If you grip the ends and then try to compress it till it buckles, the required load is greater. How the ends of a structural member are attached has a huge effect on the load the member can bear without buckling. This was discussed in detail on page 5-26. When designing trusses, as discussed later in this chapter, buckling of the compression members in a truss is of paramount importance, and indeed is one of the dominant truss failure modes.

Torsional loading: When a long shaft is subject to static torsional loads and then suddenly as the torque increases past a critical point, it deflects sideways. The criteria for this was given on page 7-22 in the context of a shaft used as a torsional spring. However, if the torque is further increased, permanent yielding may occur.

The pictures show an extreme case of what can happen if loads are dynamically applied to the structure at one of its natural frequencies: The infamous Tacoma Narrows bridge was designed with closed sections for aesthetics

and a “modern look”. However, this allowed the wind in the gorge to shed vortices off of the structure which then excited it until it crashed into the gorge.

Every structure has an infinite number of natural frequencies which will cause vibration when excited. When you push on an object and let go, it vibrates back and forth, just like plucking a guitar string. If you give the structure a push at the maximum deflection point each time, so the frequency of pushing is equal to the frequency of vibration, the vibrations will get bigger and bigger. The dynamic deflection caused by a force acting on the structure at its natural frequency, divided by the deflection that would occur if the force was applied statically, is called the *dynamic amplification factor*, or the *quality factor* Q of the structure. Damping, caused by many different factors but dominantly in machines by friction between joints, limits the Q of most structures. Still, it is not uncommon for a machine structure to have a Q of 20. This does not mean that during use the structure will become dynamically unstable and destroy itself; however, the increased deflections can cause increased loads ($F = kx$) which cause other components, such as bearings, to become overloaded and their life can thus be reduced.

The plot of response of a point on the spindle of a small grinding machine shows many such resonances. Each of these resonance corresponds to a particular mode of vibration, which means a certain part of the structure is being excited at its natural frequency. Finite element analysis is very useful at identifying the modes of vibrations, which members are deflecting most at which frequency. However, FEA is not good at predicting the amount of damping and hence Q is typically found using *experimental modal analysis*. Entire journals and conferences are dedicated to this most excellent of engineering pursuits.

In addition to load-induced stability issues, there are simple geometric stability issues. A simple example is that of tipping of a car on a slope, or of a car as it drives up an incline. What would happen if a car attempting to jump from a ramp where to slam on the brakes just after it left the ramp? Why should the driver instead rev the engine to increase the wheel speed? What is being conserved and how does it affect motion of the car?

Identify instability risks to which your machine might be susceptible!

1. See for example Brenner M.P., Lang J. H., Li J., Qiu, J., Slocum A. H., "Optimal, design of a bistable switch", PNAS, August 19, 2003, Vol. 100, No. 17, 9663-9667.

Stability

- **Static Stability:**
 - For robot contest machines, tipping-over stability is often a prime *Functional Requirement* that drives the shape of the overall structure and where the modules will be located with respect to each other
- **Dynamic stability and Buckling (see page 5-23!):**
 - Are structural resonances excited that can lead to instability and degradation of components or the process?
 - Do axial compression forces cause the component to buckle?
- **Positive uses (apply reciprocity!)**
 - Pile drivers, ultrasonic machining, triggers...

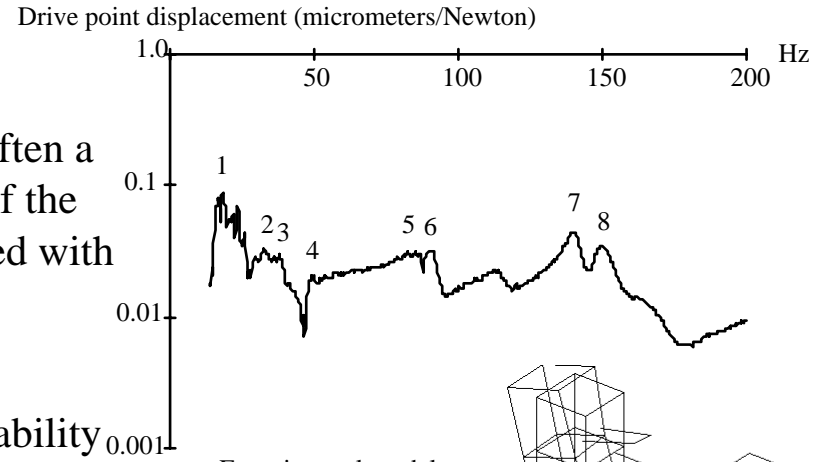

Experimental modal analysis of a small surface grinder (performed by Eric Marsh when he was Prof. Slocum's Ph.D. student)

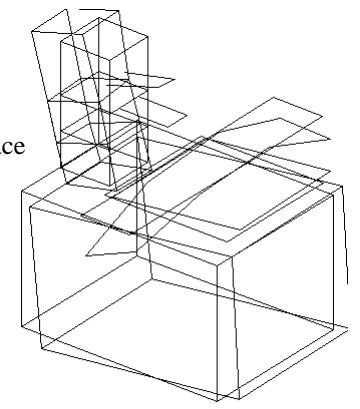

Mode 7: Table bending

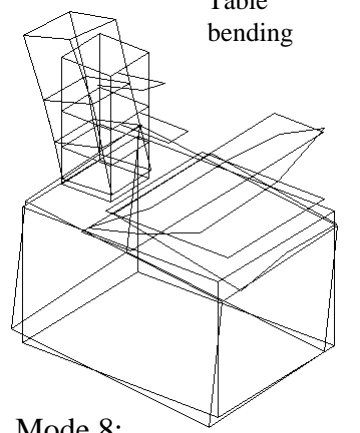

Mode 8: Column bending

L

Jammed!

<http://www.eng.iastate.edu/explorer/Bridge/collapse.htm>

Stability: Driving Over Obstacles

Many a robot has been frustrated by trying to climb over a simple obstacle, so doing the analysis before the robot is built can save a lot of grief. As shown in the diagram, the first condition for driving over an obstacle is that both front wheels have made contact with the obstacle and that have just left the ground. Note that the diagram lumps the two rear wheels together as a set, and the two front wheels together, so if each wheel is driven by its own motor, twice the motor torque should be entered in the spreadsheet *driving_over_step.xls*.

Assuming the generic case of a four wheel drive vehicle, the unknowns are F_{Tr} , F_{Nr} , F_{Tf} , F_{Nf} , and μ . The equilibrium equations include the sum of the forces in the X and Y directions, and the sum of the moments about the contact point with the obstacle. In addition, the tangential forces equal the product of the minimum coefficient of friction μ and the normal forces. To assess the appropriateness of *Front Wheel Drive* (FWD), *Rear Wheel Drive* (RWD), or *All Wheel Drive* (AWD), the parameter γ is defined such that for FWD $\gamma_f = 1$ and $\gamma_r = 0$, for RWD $\gamma_f = 0$ and $\gamma_r = 1$, and for AWD $\gamma_f = 1$ and $\gamma_r = 1$. Then the equilibrium condition requires the coefficient of friction be greater than a minimum value in order for the machine to drive over a step:

$$\cos \theta = \frac{R-h}{R} \quad \sin \theta = \frac{\sqrt{h(2R-h)}}{R}$$

$$\sum F_x = 0 = \mu\gamma_r F_{Nr} + \mu\gamma_f F_{Nf} \cos \theta - F_{Nf} \sin \theta$$

$$\sum F_y = 0 = F_{Nr} - mg + F_{Nf} \cos \theta + \mu\gamma_f F_{Nf} \sin \theta$$

$$\sum M = 0 = -F_{Nr}(L_w + R \sin \theta) + mg(L_{cg} + R \sin \theta)$$

$$\text{Let: } A = L_{cg} + R \sin \theta \quad B = L_w - L_{cg} \quad S = \sin \theta \quad C = \cos \theta$$

$$\mu \geq \frac{-C(A\gamma_r + B\gamma_f) + \sqrt{C^2(A\gamma_r + B\gamma_f)^2 + 4\gamma_r\gamma_f ABS^2}}{2\gamma_r\gamma_f AS}$$

$$F_{Nr} = \frac{mgA}{L_w + RS} \quad F_{Nf} = \frac{mgB}{(L_w + RS)(C + \mu\gamma_f S)}$$

Note the expression for μ requires the limit to be taken if γ_r or γ_f is zero and then a conditional IF statement used. Or as noted in the spreadsheet *Driving_over_step.xls*, 1×10^{-6} can be added to each of γ_r and γ_f so the full formula can be used in the spreadsheet. The tractive effort F_T to be provided by each of the rear and front wheel sets is just the product of the minimum coefficient of friction and the normal forces F_{Nr} and F_{Nf} respectively.

Why is it so hard to climb over an obstacle when it seems like an automobile drives so easily over a curb? It turns out that if you position both front wheels against a curb and try to drive over it, you can have considerable difficulty. If, however, you place one wheel against the curb so the other three are on flat ground acting to push the one wheel up...so only one wheel at a time is being forced up the curb, then you can easily drive up the curb. Note that this is only possible if the car has a suspension (see page 5-17). As a first order estimate, if the diameter of the wheel is small compared to the distance between the wheels (use Saint-Venant), and the curb height is small compared to the wheel diameter (guess who?), then in the previous equation set, the sum of the forces in the X direction only has half of the front normal force acting to resist motion, while the other equilibrium equations remain the same; hence:

$$\sum F_x = 0 = \mu\gamma_r F_{Nr} + \mu\gamma_f F_{Nf} \cos \theta - F_{Nf} \sin \theta / 2$$

$$\mu \geq \frac{-C(A\gamma_r + B\gamma_f) + \sqrt{C^2(A\gamma_r + B\gamma_f)^2 + 2\gamma_r\gamma_f ABS^2}}{2\gamma_r\gamma_f AS}$$

$$F_{Nr} = \frac{mgA}{L_w + RS} \quad F_{Nf} = \frac{mgB}{(L_w + RS)(C + \mu\gamma_f S)}$$

Pulling the rear wheel over a step (speed bump, the machine is still horizontal as it engages the bump) is easier than pushing, so if we solve for the pushing case, conservatively, it is possible to pull over a step. Similarly, if the machine has climbed onto a platform and then needs to drag the rear wheels up, if it is a 4WD, no problem. What if it is a RWD?

Play with the spreadsheet [Driving_over_step.xls](#) and use the results to help develop your design and driving strategy!

Stability: *Obstacles*

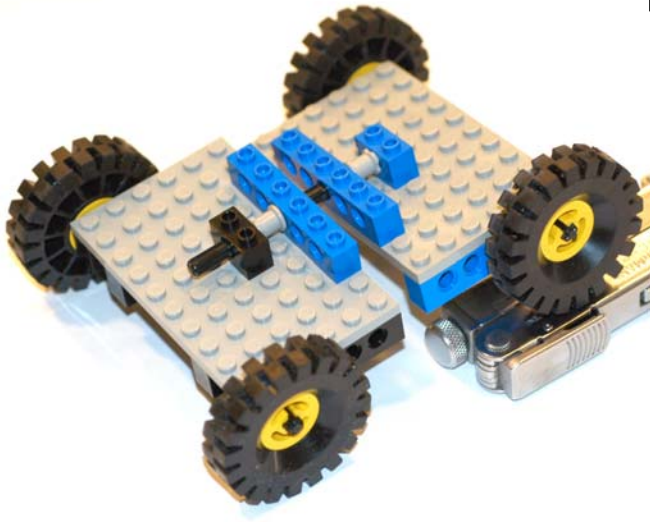

- Two wheel drive vehicles: The rear wheels have to push hard enough to make the front wheels climb the obstacle
- Four wheel drive vehicles: The rear wheels also provide the normal force needed for the front wheels to apply a tractive effort to help climb over the obstacle
- What do the free-body diagrams show about “pushing” versus “pulling” the wheels over a bump?
 - Is it better to try and climb a bump straight-on (both front wheels engage it at the same time) or one wheel at a time?
- Experiment with the spreadsheet *Driving_over_step.xls*

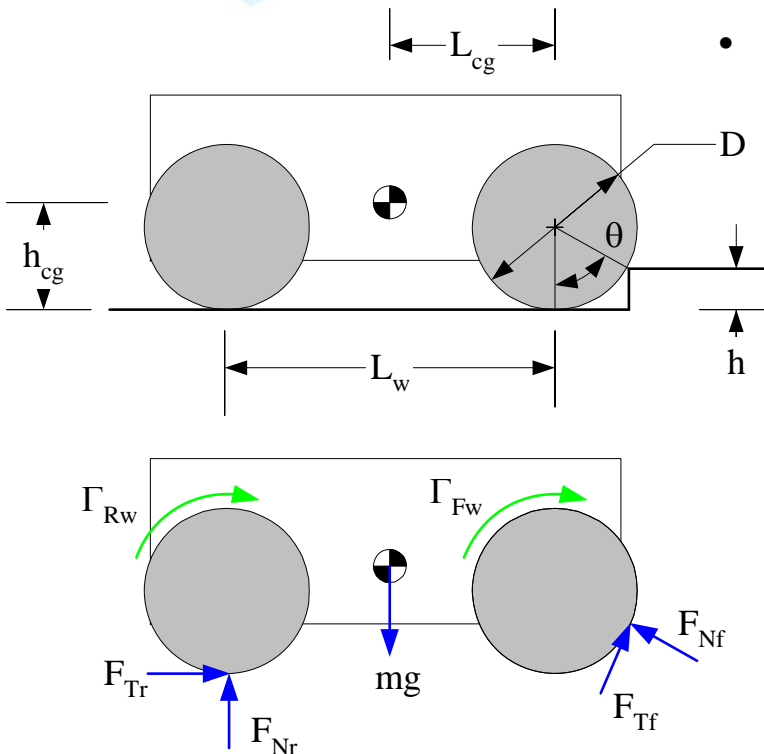

	2 wheels contact	1 wheel contact
Option 1: Nice and easy slow drive over the step		
Normal force between a rear wheel and the ground, $F_{Nr}/2$ (N)	13.9	13.9
Minimum required coefficient of friction, μ_{min2} , μ_{min1}	0.43	0.24
Normal force between a front wheel and the step $F_{Nf}/2$ (N)	11.2	13.3
Total motor tractive effort, g_m (N)	16.0	16
Total motor limited tractive force from from both rear wheels, F_{rwmax} (N)	8.0	8
Total motor limited tractive force from from both front wheels, F_{fwmax} (N)	8.0	8
Total friction limited tractive effort, g_{mu} (N)	15.1	16.3
Total friction limited tractive force from from both rear wheels before slip, $F_{rwmumax}$ (N)	8.4	8.4
Total friction limited tractive force from from both rear wheels before slip, $F_{fwmumax}$ (N)	6.7	8.0
Total minimum tractive effort required, g_{min} (N)	21.7	13.22
Total tractive effort required by both rear wheels, F_{Tr} (N)	12.06	6.77
Total tractive effort required by both front wheels, F_{Tf} (N)	9.66	6.45
Step Climable?		
Can the machine climb over the step?	no	yes
Option 2: Ramming speed!		
Ideal forward velocity required to get over the step, v (mm/s)	626	
Δ potential energy on top of step, DPE (N-m)	0.98	

Stability: Slopes & Balance

In addition to deformations of a structure, there is the issue of balance: Will the structure nominally remain in its desired position, or is there a point where the applied loads cause the structure to stop functioning. This may occur by causing the machine to lose traction, or in the more extreme case, the machine may tip over.

Assuming the generic case of a four wheel drive vehicle, the unknowns are F_{Tr} , F_{Nr} , F_{Tf} , F_{Nf} , and μ . The equilibrium equations are the sum of the forces in the X and Y directions, and the sum of the moments about the contact point with the obstacle. In addition, the tangential forces equal the product of the minimum coefficient of friction μ and the normal forces. To assess the appropriateness of *Front Wheel Drive* (FWD), *Rear Wheel Drive* (RWD), or *All Wheel Drive* (AWD), once again the parameter γ is defined such that for FWD $\gamma_f = 1$ and $\gamma_r = 0$, for RWD $\gamma_f = 0$ and $\gamma_r = 1$, and for AWD $\gamma_f = 1$ and $\gamma_r = 1$. Then the equilibrium condition requires the coefficient of friction be greater than a minimum value in order for the machine to drive up a slope;

$$\begin{aligned}\sum F_x = 0 &= \mu \gamma_r F_{Nr} + \mu \gamma_f F_{Nf} - mg \sin \theta \\ \sum F_y = 0 &= F_{Nr} + F_{Nf} - mg \cos \theta \\ \sum M = 0 &= F_{Nr} L_w - mg (L_{cg} \cos \theta + h_{mg} \sin \theta) \\ F_{Nr} &= \frac{mg (L_{cg} \cos \theta + h_{mg} \sin \theta)}{L_w} \\ F_{Nf} &= \frac{mg ((L_w - L_{cg}) \cos \theta - h_{mg} \sin \theta)}{L_w} \\ \mu &\geq \frac{L_w \sin \theta}{(\gamma_r - \gamma_f)(h_{mg} \sin \theta + L_{cg} \cos \theta) + \gamma_f L_w \cos \theta}\end{aligned}$$

Whether the machine can drive up the slope with front wheel, rear wheel, or four wheel drive can be determined by playing with the parameters γ and compare the coefficient that is required to that you have between your machine's wheels and the surface of the slope. The spreadsheet *Driving_up_slope.xls* allows you to experiment.

What about tipping over? Your intuition or experience should tell you that the machine's center of gravity should be low to the ground and as close to the uphill side of the machine as possible. Conditionally, when the normal force on the front wheels becomes zero, the gravity vector just passes through the rear wheel contact point. This causes the force F_{Nf} to become zero. Setting the equation for F_{Nf} equal to zero shows tipping occurs when:

$$\theta = \tan^{-1} \left(\frac{L_w - L_{cg}}{h_{mg}} \right)$$

What is the best location for the center of mass if there are functional requirements of being able to scale obstacles and drive up steep hills? Is four wheel drive always the best option? A low center of mass in the middle of a 4WD vehicle will produce the best design. So if you have a 4WD truck that you want to make functional for off-roading, get big tires to give the truck clearance beneath the differential housing and the ground. DO NOT jack up the suspension any more than is needed to give clearance between the tires and the wheel-wells. It may look cool but the chances of your ever needing clearance between the ground and the center of the truck are far less than your chances of rolling the vehicle!

What about driving across a slope? When will your machine tip over? Why must heavy equipment (even riding lawnmowers) be very careful driving across slopes. The machine may seem stable but hit one small bump...

Does the use of a suspension affect your decision as to where to place the center of mass, or whether or not you should have a 4WD, FWD, or RWD vehicle? What about steering, which will steer better given you probably are going to use skid-steering (where the wheels on one side are driven forward while the wheels on the other side are driven backward)?

Stability: Slopes & Balance



Funny image found on www. photographer not credited, would like to, email slocum@mit.edu

- Can the machine drive up the hill?
 - What is better for climbing hills, FWD or RWD?
 - Do you really need AWD?
- When will the machine tip over?
 - What happens when the force vector due to gravity just passes through the rear wheels ground contact points?

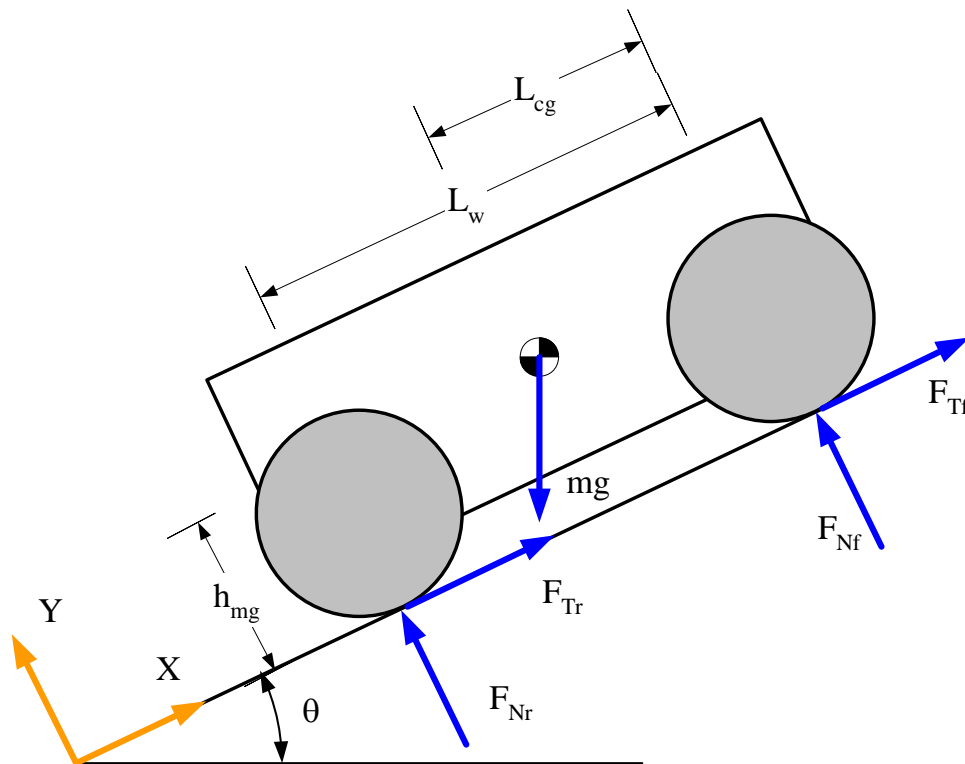

<i>Driving_up_slope.xls</i>	
System	Values
Rear wheels' diameter, Drw (mm)	100
Front wheels' diameter, Dfw (mm)	100
Distance between wheels, Lw (mm)	250
Distance center of front wheel to center of gravity, Lcg (mm)	125
Height of center of mass about plane, hmg (mm)	50
Slope angle, theta (deg, rad)	20.00 0.35
Machine mass, m (kg)	4
Machine weight, mg (N)	39.2
Maximum drive torque applied to both rear wheels, grw (N-mm)	400
Maximum drive torque applied to both front wheels, gfw (N-mm)	400
Coefficient of friction, mu	0.5
for FWD $\gamma_f = 1$ and $\gamma_r = 0$, for RWD $\gamma_f = 0$ and $\gamma_r = 1$, and for AWD $\gamma_f = 1$ and $\gamma_r = 1$	
Enter 1 for rear wheel drive or AWD, γ_r	1
Enter 1 for front wheel drive or AWD, γ_f	1
Nice and easy slow drive up the ramp (no acceleration)	
Normal force between both rear wheels and ground, FNr (N)	21.1
Normal force between both front wheels and step FNf (N)	15.7
Maximum rear wheel tractive force from drive torque, Frwmax (N)	8
Maximum rear wheel force from drive torque, Ffwmax (N)	8
Maximum rear wheel tractive force before slip, Frwmumax (N)	10.5
Maximum front wheel tractive force before slip, Ffwmumax (N)	7.9
Total tractive force generated by both rear wheels, FTTr (N)	8.00
Total tractive effort required by both front wheels, FTf (N)	7.87
Total tractive effort of the machine, FTm (N)	15.87
Force from gravity acting along the incline, Fg (N)	13.41
Can the machine climb up the ramp?	yes
Tip-over angle (deg, rad)	68.2 1.19
Required minimum friction coefficients:	
Front wheel drive only required coefficient of friction	0.85
Rear wheel drive only required coefficient of friction	0.64
All wheel drive required coefficient of friction	0.36

Loadings: Axial, Bending, Torsion, & Shear

As shown, there are four basic types of loading, and in combination, they essentially create all the different types of loads to which a structure can be subjected. As discussed on page 3-23, superposition allows us to consider the effects of one load type at a time, and then the combinatorial effect of all the stresses created by all the loads can be assessed using the von Mises equivalent stress criteria. Different types of materials fail in different ways, but for ductile metals, those most often used in machines such as robots, the von Mises equivalent stress can be equated to the tensile yield stress for a material in order to determine when it will fail.¹

Novice engineers most often overlook boundary conditions, or make incorrect loading assumptions. When is a structure anchored so there is a defined angle to another structure? When does it act as if it is pinned, or free to rotate at the point of attachment? Often reality lies somewhere in-between, and an engineer may want to err on the conservative side for initial estimations, and then use finite element analysis in the detailed design phase. As an example, consider a structure where two beams project out of a wall at right angles as shown. If the top beam merely rests on the lower beam, then no moments are transmitted to the lower beam, and the applied force F is shared by both beams. There are five basic steps to analyzing structures:

- Draw the free-body diagram of the system, and clearly label the forces, moments, and displacements.
- Identify the knowns and unknowns of the problem.
- Write down the boundary conditions (geometric *compatibility*).
- Write down the force and moment *equilibrium* equations.
- Write down the *constitutive* relations (e.g., how deflection relates to force and geometry).

1. *Fracture* which occurs when high stresses either initiate a crack, or when stresses applied to a defect in the structure start a crack tip growing. The finite element analysis figures show how stresses increase around sharp geometric features, so imagine what happens when a very sharp crack exists. Crack tips, however, can be blunted by other defects, inclusions (alloying elements) or geometric features (holes). Other factors such as cold temperatures can embrittle certain metals, such as many ferritic alloys, while austenitic metals, such as aluminum and some stainless steels, are not subject to temperature embrittlement. The study of how fractures occur is called *fracture mechanics*, and it is by the skill of those in this field that planes keep flying!

The number of unknown variables should equal the number of equations obtained from the compatibility, equilibrium, and constitutive relations. For the example of the two beams at right angles to each other:

unknowns: $F_1, F_2, M_1, M_2, \delta_1, \delta_2, \theta_1, \theta_2, \phi_1, \phi_2$

compatibility: $\delta_1 = \delta_2 \quad \theta_1 = \phi_2 \quad \theta_2 = \phi_1$

constitutive:

$$\delta_1 = \frac{F_1 L_1^3}{3E_1 I_1} + \frac{M_1 L_1^2}{2E_1 I_1} \quad \delta_2 = \frac{F_2 L_2^3}{3E_2 I_2} + \frac{M_2 L_2^2}{2E_2 I_2}$$

$$\theta_1 = \frac{F_1 L_1^2}{2E_1 I_1} + \frac{M_1 L_1}{E_1 I_1} \quad \theta_2 = \frac{F_2 L_2^2}{2E_2 I_2} + \frac{M_2 L_2}{E_2 I_2}$$

$$\phi_1 = \frac{M_2 L_1}{G_1 I_{P1}} \quad \phi_2 = \frac{M_1 L_2}{G_2 I_{P2}} \quad G = \frac{E}{2(1+\nu)}$$

equilibrium:

$$F_1 + F_2 = F$$

Assume the beams are the same length L and diameter D , then by symmetry, the force will be evenly distributed between them ($F_1 = F_2 = F/2$) and $M_1 = M_2$. The ratio of the fixed ends deflection to the free-ends deflection is 3.6:1. If, for example, the thickness of the beam varies with position along the beam, one often starts with the basic differential equations of beam bending. Nonlinear effects, such as a bending beam encountering a curved surface, can also be included as a boundary conditions. The differential equations can then be solved numerically using a program such as MATLAB². If one just relies on finite element analysis to analyze a system one has drawn on the solid modeler, then one loses massive potential for using analysis to drive creative solutions. For example, having the general form of the equations and using optimization routines, can lead to shaped beams with far superior properties than could be imagined by an FEA-limited engineer³.

What are your boundary conditions?!

2. See for example Li, J, Brenner, M., Lang, J., Slocum, A. "DRIE Etched Electrostatic Curved-Electrode Zipping Actuators", JMEMS

3. Brenner M.P., Lang J. H., Li J., Qiu, J., Slocum A. H., "Optimal design of a bistable switch", PNAS, August 19, 2003, Vol. 100, No. 17, 9663-9667.

Loadings: *Axial, Bending, Torsion, & Shear*

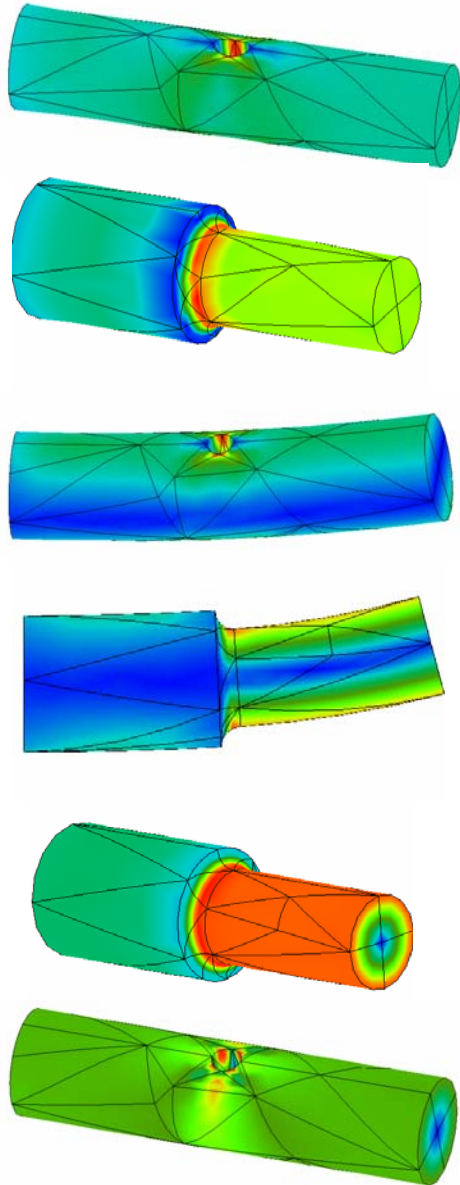

- There are four basic types of loads:
 - *Axial tension or compression*: the applied force directly acts on the material to cause tension or compression
 - *Bending*: an applied force acts via a lever to bend a beam, causing tension on one side and compression on the other side of the structure
 - *Torsion*: a torque (e.g., twisting or two equal and opposite forces applied about a point) causes twist of the structure
 - *Shear*: two equal and opposite essentially collinear forces act perpendicular to a structure
 - Structures that fail in torsion are actually also failing in shear
 - Glue joints in laminates, subjected to bending, actually fail in shear
- Boundary conditions are critical!

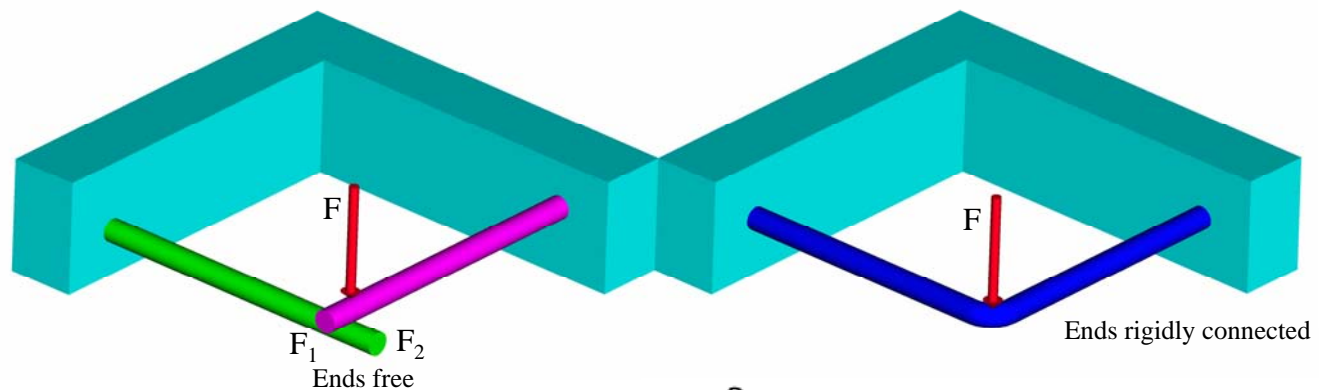

For equal diameter and length beams:

$$\frac{\delta_{\text{ends of beams joined}}}{\delta_{\text{one beam resting on the other}}} = \frac{5+4\nu}{4(2+\nu)}$$

Loadings: *Structural Cross-Sections*

The shape of a structural cross-section has a huge effect on its strength and stiffness. As shown, the formulas can be quite complex, but they are easily encoded in a spreadsheet to enable a design engineer to play “what-if” scenarios. This represents a basic starting set used by most design engineers. As a design engineer’s focus and experience grows, other structural sections unique to their application can be added.¹

The spreadsheets *Section_Round_Rectangle.xls*, *Section_angle.xls*, *Section_channel.xls*, and *Section_I.xls* are provided for the reader to experiment with different cross-sections. In general, if torsional stiffness or strength is desired, then a closed section, preferably circular, should be used. If maximum bending strength is to be obtained, then an I-beam or rectangular tube is best. It is a simple exercise for the reader to create spreadsheets for the generic open and closed sections shown. Furthermore, these spreadsheets present just the starting point, and the reader can customize them to include calculations for different bending or torsional boundary conditions.

In creating the spreadsheets for various sections, the formula assume that the inscribed circle diameter D is known, but this is not typically given by the manufacturer of structural shapes. A good geometry refresher is to calculate the diameter of the inscribed circle in the corners of angles, channels, and I-beams. As with any problem, start with a sketch, add known dimensions and boundary conditions, and label the unknowns. As shown in the small figure, this quickly leads to an equation based on the Pythagorean theorem: The diameter is then found using the quadratic formula:

$$\left(d + r - \frac{D}{2}\right)^2 + \left(b + r - \frac{D}{2}\right)^2 = \left(r + \frac{D}{2}\right)^2 \quad \text{let } R = \frac{D}{2}$$

$$R^2 + R(-6r - 2d - 2b) + (b^2 + d^2 + r^2 + 2r(b + d)) = 0$$

1. The formula for the effective torsional moment of inertia were developed from equations given in R. Roark and W. Young *Formulas for Stress and Strain*, Fifth Edition, Mcgraw-Hill Book Company, NY, pp 290-296. Additional formulas for various bending and torsional beam end constraints can also be found. A slightly more advanced topic, not covered here, but easy to investigate, is the *shear center* of a non-symmetric section. For example, if a channel section is loaded with the force normal to its flange, the strong direction, it will also twist unless the load is applied through the shear center. See page 194 of Roark. No design engineer should be without a Roark!

Finite element analysis is a great tool, but until the structure is designed, you need analytical and practical intuition of how shapes’ geometry affects strength and stiffness. For example, use the spreadsheet *round_rectangle_strength.xls* to conduct a design study: what to use, a round or square tube for a waterjet cutter’s main structural axes?² If we pick a constant size, and vary the wall thickness to maintain constant area (weight):

Tube	Size (mm)	Wall thickness	Area	I_{bending}	I_{torsion}
Round	100	10	2827	2898119	5796238
Square	100	7.65	2826	4044369	6025209
ratio	1.00	1.31	1.00	0.72	0.96

Whereas if we are constrained by size, such as by a maximum bellows size, what is the biggest section that will fit inside a given circular bellows diameter:

Tube	Size (mm)	Wall thickness	Area	I_{bending}	I_{torsion}
Round	100	10	2827	2898119	5796238
Square	70.7	12.05	2827	1689839	2432178
ratio	1.41	0.83	1.00	1.72	2.38

On the other hand, if the wall thickness is made the same and the size of the steel tube selected to once again obtain the same cross sectional area:

Tube	Size (mm)	Wall thickness	Area	I_{bending}	I_{torsion}
Round	100	10	2827	2898119	5796238
Square	80.7	10	2827	2400573	3530185
ratio	1.24	1.00	1.00	1.21	1.64

Is it surprising that in many cases, a round beam is actually better than a square beam? What if an I-beam were used? It all really depends on the functional requirements of the system. Many a design opportunity was missed because of reliance on old or inappropriate generalizations!

2. This question confronted the author when he created the design concept for the OMAX 2652 Abrasive Waterjet Machining Center. See www.omax.com

Be thankful for spreadsheets!

Loadings: Structural Cross-Sections

$$K_{\text{torsional stiffness}} = \frac{GI_P}{L}$$

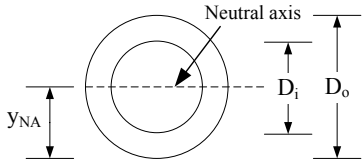

$$y_{NA} = \frac{D_o}{2} \quad I_{\text{bending}} = \frac{\pi(D_o^4 - D_i^4)}{64} \quad I_{\text{torsion}} = \frac{\pi(D_o^4 - D_i^4)}{32} \quad \tau_{\text{max}} = \frac{D_o \Gamma}{2I_{\text{torsion}}}$$

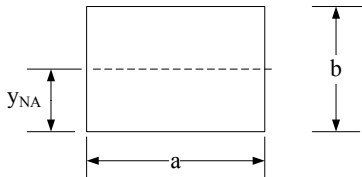

$$y_{NA} = \frac{b}{2} \quad I_{\text{bending}} = \frac{ab^3}{12} \quad I_{\text{torsion}} = \frac{ab}{12}[a^2 + b^2] \quad \tau_{\text{max}} = \frac{4.8\Gamma}{a^3}$$

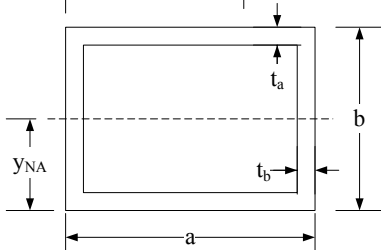

$$y_{NA} = \frac{b}{2} \quad I_{\text{bending}} = \frac{ab^3 - (a-2t_b)(b-2t_a)^3}{12} \quad I_{\text{torsion}} = \frac{2t_a t_b (a-t_b)^2 (b-t_a)^2}{a t_b + b t_a - t_a^2 - t_b^2} \quad \tau_{\text{max short side}} = \frac{\Gamma}{2t_b (a-t_b)(b-t_a)}$$

$$I_{\text{torsion with } a=b \text{ and uniform thickness } t} = t(b-t)^3 \quad \tau_{\text{max long side}} = \frac{\Gamma}{2t_a (a-t_b)(b-t_a)}$$

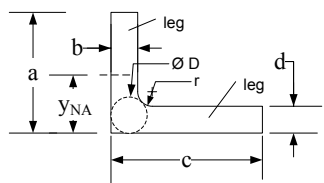

$$y_{NA} = \frac{a^2 b + d^2 (c-b)}{2(ab + d(c-b))} \quad I_{\text{bending}} = ab \left[\frac{a^2}{12} + \left(\frac{a}{2} - y_{NA} \right)^2 \right] + d(c-b) \left[\frac{d^2}{12} + \left(\frac{d}{2} - y_{NA} \right)^2 \right] \text{ Ignore } r \text{ in } I_{\text{bending}} \text{ calculations}$$

$$I_{\text{torsion}} = ab^3 \left[\frac{1}{3} - 0.21 \frac{b}{a} \left(1 - \frac{b^4}{12a^4} \right) \right] + (c-b)d^3 \left[\frac{1}{3} - 0.105 \frac{d}{c-b} \left(1 - \frac{b^4}{192(c-b)^4} \right) \right] + D^4 \frac{d}{b} \left(0.07 + 0.076 \frac{r}{b} \right)$$

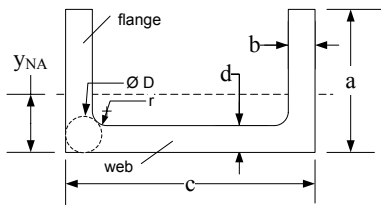

$$y_{NA} = \frac{2a^2 b + d^2 (c-2b)}{2(2ab + d(c-2b))} \quad I_{\text{bending}} = 2ab \left[\frac{a^2}{12} + \left(\frac{a}{2} - y_{NA} \right)^2 \right] + d(c-2b) \left[\frac{d^2}{12} + \left(\frac{d}{2} - y_{NA} \right)^2 \right] \text{ Ignore } r \text{ in } I_{\text{bending}} \text{ calculations}$$

$$I_{\text{torsion}} = 2 \left\{ ab^3 \left[\frac{1}{3} - 0.21 \frac{b}{a} \left(1 - \frac{b^4}{12a^4} \right) \right] + \left(\frac{c}{2} - b \right) d^3 \left[\frac{1}{3} - 0.105 \frac{d}{c/2 - b} \left(1 - \frac{b^4}{192(c/2 - b)^4} \right) \right] + D^4 \frac{d}{b} \left(0.07 + 0.076 \frac{r}{b} \right) \right\}$$

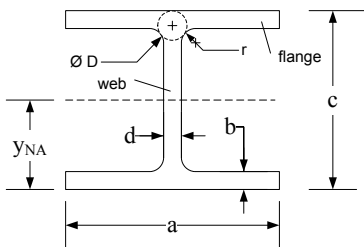

$$y_{NA} = \frac{c}{2} \quad I_{\text{bending}} = \frac{ac^3 - (a-2d)(c-2b)^3}{12}$$

$$I_{\text{torsion}} = 2 \left\{ ab^3 \left[\frac{1}{3} - 0.21 \frac{b}{a} \left(1 - \frac{b^4}{12a^4} \right) \right] + \left(\frac{c}{2} - b \right) d^3 \left[\frac{1}{3} - 0.105 \frac{d}{c/2 - b} \left(1 - \frac{b^4}{192(c/2 - b)^4} \right) \right] + D^4 \frac{d}{b} \left(0.15 + 0.10 \frac{r}{b} \right) \right\}$$

$$I_P = \frac{4A_{\text{mean of areas enclosed by boundaries}}^2 t_{\text{thickness}}}{P_{\text{length of median boundary}}}$$

$$\tau_{\text{average shear stress}} = \frac{\Gamma}{2tA}$$

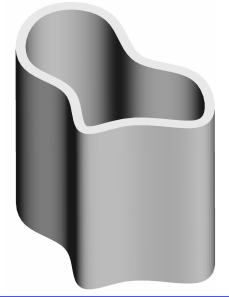

$$I_P = \frac{P_{\text{length of median boundary}} t^3_{\text{thickness}}}{3}$$

$$\tau_{\text{average shear stress}} = \frac{\Gamma(3P + 1.8t)}{P^2 t^2}$$

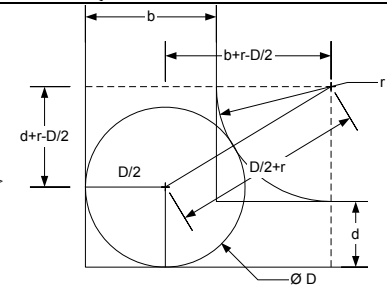
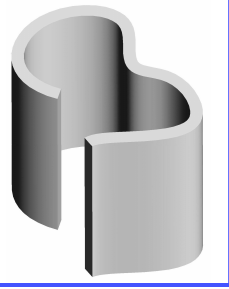

Stiffness (1/Compliance)

When designing a structure for accuracy, achieving high stiffness is typically of primary importance. When designing for ergonomics, stiffness may have to be high or low depending on the design's functional requirements. Hence understanding the philosophy behind achieving the desired stiffness is of greatest importance. It is therefore so important to once again review the **FUNdaMENTAL** principles of Topic 3, and in particular, *Saint-Venant's principle* and the *principle of Structural Loops*. Also beware Maudslay's maxim from page 1-4: *Keep a sharp look-out upon your materials: get rid of every pound of material you can do without. Put yourself to the question, 'What business has it there?'*

For example, it is a straightforward calculation to determine the deflection and stiffness of a uniform cantilever beam to be used as a spring. Adding taper complicates the calculation (see page 7-24); however, the taper angle employs Maudslay's Maxim to get rid of material that is not being strained as much as the material at the base of the cantilever. When the beam is tapered, it is lighter, and more compliant.

As discussed on the next page, there are a number of simple cases for which closed-form solutions exist to predict deflections of beams under various loading conditions. However, there are two real-world issues that must be considered when applying these formulas: *machine elements & joints*, and *boundary conditions*. Occam and Maudslay would implore us to make all elements of a design have a similar effect on total system stiffness, lest one element be over or under-designed. Therefore, during the initial concept stage before the bearings or joints are designed in detail, but while the structure is being laid out, one can assume that each will contribute equally to the net system compliance (remember, compliance is 1/stiffness!). Hence with regard to initial layout calculations, the structure itself should be 2-3 times stiffer than the net desired system stiffness. 2 or 3, that is the question! If there are few joints, use 2. If there are a lot of joints, use 3. This is where experience must be established with practice!

Boundary conditions can also be vexing, because an object is rarely truly clamped or simply supported. If you cannot tell, then reality is probably somewhere in-between, and you can model the system as having a stiffness that is the average of the simply supported and clamped conditions. Then in the

detailed design phase, finite element analysis comes to the rescue. Shown are the colored outputs from finite element analysis of various structures and assemblies designed by the author. Each of these designs were first created using first order analysis techniques such as have been discussed. This allowed for the initial feasibility determination and then sizing of the elements. Next solid models were created with all the detailed nuances such as rounded corners and bearings and joints. Then the solid model assembly was used by the FEA program.

The solid models and FEA results show a silicon microcantilever for electrical contacts, a 4-bar linkage made from flexing elements, and the Z-axis portion of a robot for use in a semiconductor testing device. The former illustrate designs where large compliance is required so the components essentially behave like spring-guided stages. The latter illustrates the desire to minimize compliance, because if the structure deforms too much under load, then the robot would not be able to achieve its desired accuracy. What would a design engineer do if given the space constraints, the *risk* of too-large deflections was too great? As a countermeasure, one could use low-friction rolling element bearings to make sure the deflections were repeatable. The force could also be determined using load sensors, or measurement of the current in the motor that drives the Z-axis ballscrew. Software-based error compensation could then be used to correct for deflections caused by the force.

With regard to machines for design contests and low-cost machines, a simple piece of sheet-metal makes a very poor frame if its deflection causes clearances between machine elements to close and bind. High compliance might be acceptable for plastic lawn furniture, but not for durable machinery!

Do a stiffness review of your machine by imagining each element in the structure is made of soft rubber. How does its deflection ripple through the machine? Do deflections cause Abbe (sine) errors that can cause machine elements to jamb, or gear teeth to skip? Formulate a plan to determine deflections, assess the risks, and develop countermeasures. Can you add diagonal braces or ribs? Can you increase clearances?

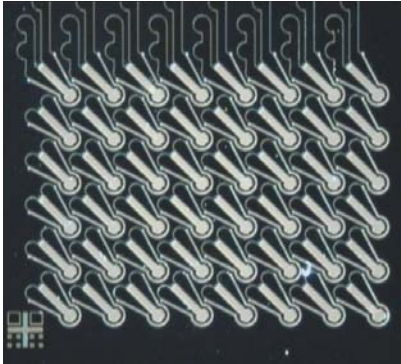

Width-tapered silicon springs

Stress Von Mises (Maximum)
 Avg. Max +3.1839E+05
 Avg. Min +5.8269E+01
 Deformed Original Model
 Max Disp +7.0545E-03
 Scale 5.2100E-01
 Load: load1

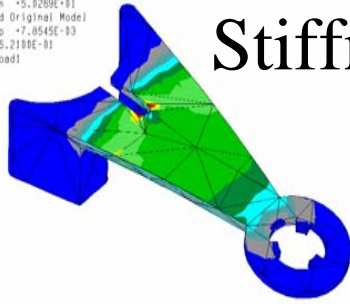

Stiffness (1/Compliance)

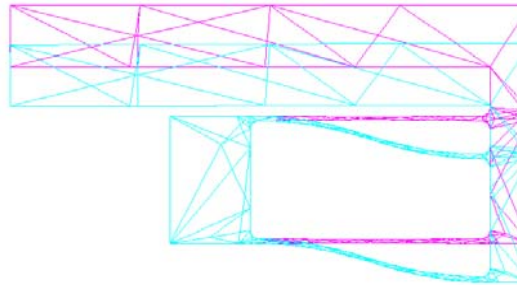

Displacement Z
 Max +3.1979E-03
 Min -1.7279E-04
 Deformed Original Model
 Max Disp +3.6824E-03
 Scale 8.0111E+02
 Load: load1

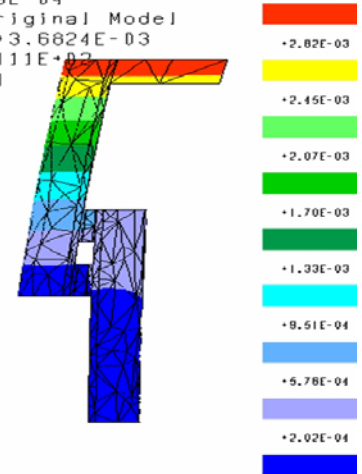

- All structures deform under load
 - Will the deformations create translational and angular displacements that will cause other elements to become overloaded or interfere and then fail?
 - Make the deflection 3-5x LESS than critical clearances (Saint-Venant)
- Where are forces transmitted between members with respect to their neutral axes?
 - Position interface contact points at neutral axis planes!
- System compliance = sum of structural and element compliances
 - Machine elements (e.g., bearings) and joints should have a stiffness on the order of the structure itself
 - During early design stage, before bearings and joints are designed, assume net stiffness will thus be structural stiffness/3

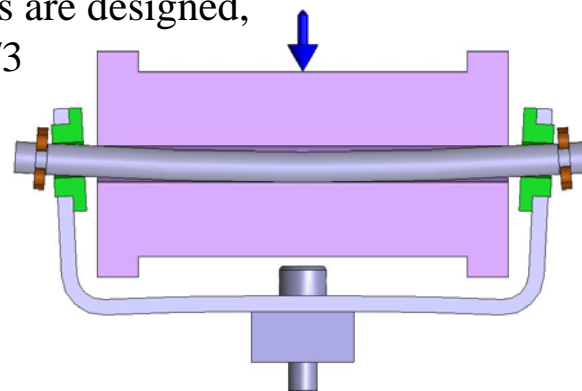
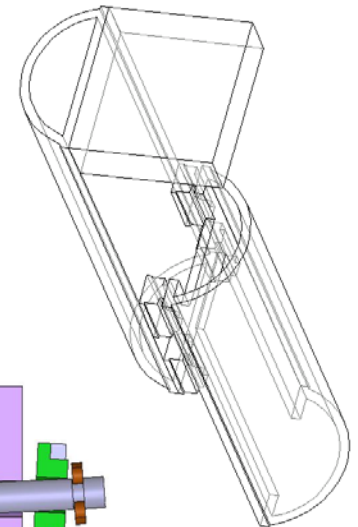

Stiffness: *First-Order Analysis*

It is important to be able to rapidly evaluate different design concepts, which often requires first order analysis of a structure. Shown are some very common beam mounting and loading conditions, and the resulting maximum bending moments and deflections. Of course there are many other conditions, including for plates and curved members that also have closed-form solutions. A practising design engineer should keep a copy of R. Roark and W. Young [Formulas for Stress and Strain](#), (Mcgraw-Hill Book Company, NY,) on their desk for easy reference!

For these most common mountings shown, spreadsheets are provided for beams of uniform cross section: *Beam_Cantilever.xls*, *Beam_Simply_Supported.xls*, *Beam_Fixed_Simply_Supported.xls*, and *Beam_Fixed_fixed.xls*. These spreadsheets allow for the input of point, distributed, and moment loads. For the distributed load, w_a is the magnitude of the distributed load at one end, and w_L is the magnitude at the other end; hence a triangular load profile can be input. The reaction forces at the boundaries are R_A and R_B , and the reaction moments are M_A and M_B . The slopes and deflections at the boundaries are θ_A , θ_B and δ_A , δ_B respectively. In combination, the moment, slope, and deflection are given at any point along the beams. To obtain different loading profiles, superposition can be used. Numerical and graphical outputs are provided as shown.

The equations shown are impossibly complex with respect to spotting trends. However, consider the simplified special cases for a force or a moment applied to the end of a cantilevered beam shown on the bottom of the page. As a design engineer trained to recognize patterns, what do you notice about the deflection and slope relations for a cantilever beam loaded by a force F or a moment M ? Dr. William Plummer at Polaroid had a need for a fixture to adjust the pitch and roll of a lens in a calibration fixture without creating any translational displacement. A fancy company tried to sell then a stacked cradle system for tens of thousands of dollars. Dr. William Plummer remembered his fundamentals of beam bending and used reciprocity to make an Abbe error cancel a displacement error! This exemplifies that although computer aided design tools may be useful for rapidly evaluating a design concept, they do not usually provide creative insight as does the knowledge of fundamentals.

Beam_Fixed_Fixed.xls	
To determine deflection of a beam	
By Alex Slocum, last modified 12/28/03 by Alex Slocum	
Enters numbers in BOLD , Results in RED	
Beam	
Length, L (mm)	100
Length increment, Linc (mm)	1
Modulus of elasticity, E (N/mm ²)	200000
Moment of inertia, I (mm ⁴)	450
Distance farthest fiber to neutral axis, cc (mm)	3
Loading	
Point load, F (N)	100
Location of point load, af (mm)	50
Distributed load amplitude, wa, (N/mm)	0
Distributed load amplitude, wL, (N/mm)	0
Starting point of load, aw (mm)	50
Moment load, M (N-mm)	0
Location of moment load, am (mm)	50
Maximum deflection (microns)	-5.8
Maximum slope (radians)	-0.174
Reactions at beam ends	
R _A , R _a (N)	50.000
R _B , R _b (N)	50.000
M _A , M _a (N)	-1250.000
M _B , M _b (N-mm)	-1250.000

Review the structure of your machine. How would you use superposition of basic mountings to model the primary elements? What are the biggest unknowns, boundary conditions or applied loads? How can you make reasonable conservative assumptions? How can you test them? (build and try!)

Stiffness: *First-Order Analysis*

- Complex systems can often be modeled by superimposing simple models

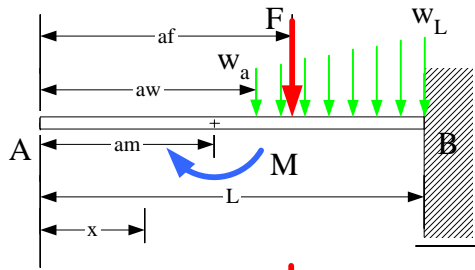

$$R_B = F + \frac{(w_L + w_a)(L-a)}{2} \quad M_B = -F(L-a) - \frac{(L-a)^2}{2} \left[w_a + \frac{(w_L - w_a)}{3} \right] + M$$

$$\theta_A = \frac{F(L-a)^2}{2EI} + \frac{(L-a)^3}{6EI} \left[w_a + \frac{(w_L - w_a)}{4} \right] - \frac{M(L-a)}{EI}$$

$$\delta_A = \frac{-F(2L^3 - 3aL^2 + a^3)}{6EI} - \frac{(L-a)^3}{24EI} \left[w_a(3L+a) + \frac{(w_L - w_a)(4L+a)}{5} \right] + \frac{M(L^2 - a^2)}{2EI}$$

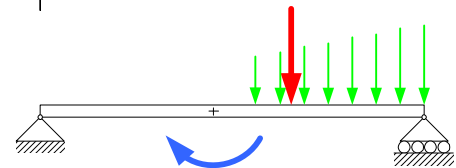

$$R_A = \frac{F(L-a)}{L} + \frac{(L-a)^2(w_L + 2w_a)}{6L} \quad R_B = \frac{Fa}{L} + \frac{(L-a)}{2} \left[w_L + w_a - \frac{(L-a)(w_L + 2w_a)}{3L} \right] + \frac{M}{L}$$

$$\theta_A = \frac{-Fa(L-a)(2L-a)}{6EIL} - \frac{(L-a)^2}{24EIL} \left[w_a(L^2 + 2aL - a^2) + \frac{(w_L - w_a)(7L^2 + 6aL - 3a^2)}{15} \right] - \frac{M(2L^2 - 6aL + 3a^2)}{6EIL}$$

$$\theta_B = \frac{Fa(L^2 - a^2)}{6EIL} + \frac{1}{24EIL} \left[w_a(L^2 - a^2)^2 + \frac{(w_L - w_a)(L-a)^2(8L^2 + 9aL + 3a^2)}{15} \right] + \frac{M(L^2 - 3a^2)}{6EIL}$$

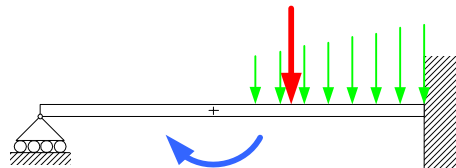

$$R_A = \frac{F(L-a)^2(2L+a)}{2L^3} + \frac{(L-a)^3}{8L^3} \left[w_a(3L+a) + \frac{(w_L - w_a)(4L+a)}{5} \right] - \frac{3M(L^2 - a^2)}{2L^3} \quad R_B = \frac{Fa(3L^2 - a^2)}{2L^3} + \frac{(w_L + w_a)(L-a)}{2} - \frac{(L-a)^3}{8L^3} \left[w_a(3L+a) + \frac{(w_L - w_a)(4L+a)}{5} \right] + \frac{3M(L^2 - a^2)}{2L^3}$$

$$M_B = \frac{-Fa(L^2 - a^2)}{2L^2} + \frac{(L-a)^3}{8L^2} \left[w_a(3L+a) + \frac{(w_L - w_a)(4L+a)}{5} \right] - \frac{(L-a)^2}{2} \left[w_a + \frac{(w_L - w_a)}{3} \right] + \frac{M(3a^2 - L^2)}{2L^2}$$

$$\theta_A = \frac{-Fa(L-a)^2}{4EIL} - \frac{(L-a)^3}{48EIL} \left[w_a(L+3a) + \frac{(w_L - w_a)(2L+3a)}{5} \right] + \frac{M(L-a)(3a-L)}{4EIL}$$

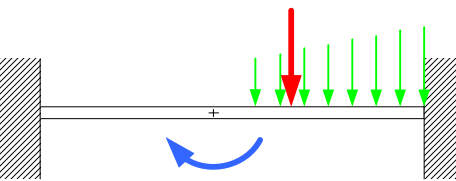

$$R_A = \frac{F(L-a)^2(L+2a)}{L^3} + \frac{(L-a)^3}{2L^3} \left[w_a(L+a) + \frac{(w_L - w_a)(3L+2a)}{10} \right] - \frac{6Ma(L-a)}{L^3} \quad R_B = \frac{Fa^2(3L-2a)}{L^3} + \frac{(w_L + w_a)(L-a)}{2} - \frac{(L-a)^3}{2L^3} \left[w_a(L+a) + \frac{(w_L - w_a)(3L+2a)}{10} \right] + \frac{6Ma(L-a)}{L^3}$$

$$M_A = \frac{-Fa(L-a)^2}{L^2} - \frac{(L-a)^3}{12L^2} \left[w_a(L+3a) + \frac{(w_L - w_a)(2L+3a)}{5} \right] - \frac{M(L^2 - 4aL + 3a^2)}{L^2}$$

$$M_B = \frac{-Fa^2(L-a)}{L^2} + (L-a)^2 \left\{ \frac{(L-a)}{2L^2} \left[w_a(L+a) + \frac{(w_L - w_a)(3L+2a)}{10} \right] - \frac{w_a(L+3a)}{6} - \frac{(w_L - w_a)(2L+3a)}{30} \right\} - \frac{Ma(3a-2L)}{L^2}$$

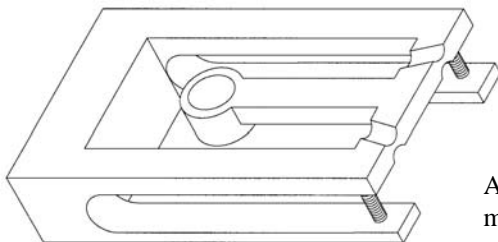

Abbe errors exist, but reciprocity says they might be usable... Do you see a pattern?

$$\delta = \frac{FL^3}{3EI} \quad \alpha = \frac{FL^2}{2EI} \quad \delta = \frac{ML^2}{2EI} \quad \alpha = \frac{ML}{EI}$$

To see the plots in full, see the spreadsheets!

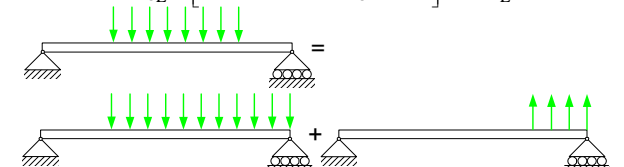
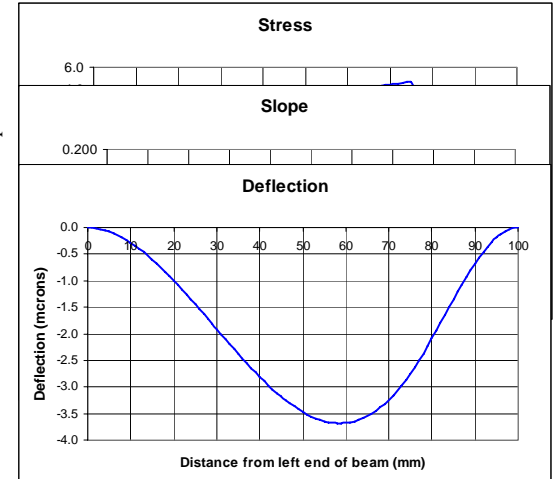

Transverse shear $V = R_A - F\langle x-a \rangle^0 - w_a\langle x-a \rangle - \frac{(w_L - w_a)\langle x-a \rangle^2}{2(L-a)}$

Moment $M = M_A + R_Ax - F\langle x-a \rangle - \frac{w_a\langle x-a \rangle^2}{2} - \frac{(w_L - w_a)\langle x-a \rangle^3}{6(L-a)} + M\langle x-a \rangle^0$

Slope $\theta = \theta_A + \frac{M_Ax}{EI} + \frac{R_Ax^2}{2EI} - \frac{F\langle x-a \rangle^2}{2EI} - \frac{w_a\langle x-a \rangle^3}{6EI} - \frac{(w_L - w_a)\langle x-a \rangle^4}{24EI(L-a)} + \frac{M\langle x-a \rangle}{EI}$

Displacement $\delta = \delta_A + \theta_Ax + \frac{M_Ax^2}{2EI} + \frac{R_Ax^3}{6EI} - \frac{F\langle x-a \rangle^3}{6EI} - \frac{w_a\langle x-a \rangle^4}{24EI} - \frac{(w_L - w_a)\langle x-a \rangle^5}{120EI(L-a)} + \frac{M\langle x-a \rangle^2}{2EI}$

Stiffness: Analytical Methods

Most design engineers can make do with equations from a handbook or by modifying pre-made spreadsheets such as those provided with this book. Sometimes, however, more powerful analytical tools are needed to help synthesize or optimize a new design. Finite element analysis is a powerful tool, but often does not provide the insight afforded by fundamental analysis unless you take the time to set up a parametric design study. For example, the equations shown on the previous page were developed from the general differential equation of the elastic curve formed by a bending beam:

$$\begin{aligned} \frac{dy}{dx} = \theta &\Rightarrow EI \frac{d^2y}{dx^2} = M &\Rightarrow \frac{d}{dx} EI \frac{d^2y}{dx^2} = V &\frac{d^2}{dx^2} EI \frac{d^2y}{dx^2} = q \\ y' = \theta &\Rightarrow EIy'' = M &\Rightarrow (EIy'')' = V &(EIy''') = q \end{aligned}$$

The moment M is typically a function of position x along the beam. An important task, therefore, is to find the expression for the moment M as a function of the loading parameters, such as point forces and distributed loads, and their point of application along the beam. The load intensity function q allows for the creation of an expression where loads are applied at different points. The solution of the differential equations depends primarily on the boundary conditions. In addition, starting from this basic form allows for the use of an expression for the moment of inertia I as a function of position x , as is the case with a tapered beam. In addition, the displacement y can have boundary conditions imposed, such as a beam coming into contact with surface.¹

In order to formulate the load intensity function q , singularity functions allow loads to be “turned on” at a desired point. The figure shows how this is done for different loading conditions. For example, the unit step function is given by $\langle x - a \rangle^0$ where the use of the angle brackets $\langle \rangle$ is defined as: If $x < a$, $\langle x - a \rangle^0 = 0$. If $x > a$, then $\langle x - a \rangle^0 = 1$. The integration law is:

$$\int_{-\infty}^x \langle x - a \rangle^n dx = \frac{\langle x - a \rangle^{n+1}}{n+1} \quad n \geq 0 \quad \int_{-\infty}^x \langle x - a \rangle_n dx = \langle x - a \rangle_{n+1} \quad n < 0$$

1. This creates a hardening spring effect. See Brenner, M., Lang, J., Li, J., Slocum, A., "Optimum Design of an Electrostatic Zipper Actuator", Nanotech 2004, Boston

In the mid 19th century, Alberto Castigliano was a student at the Polytechnic University in Turin Italy, and he developed an energy-based method for determining the deflection of elastic structures.² A small change in applied load Q results in a small change in the displacement Δ . Since work (energy) is the product of force and displacement, the change in energy can be obtained by calculating the change in area on a force-displacement graph. As dQ is made infinitesimally small:

$$dU' = dU = \Delta dQ \quad \Rightarrow \Delta = \frac{dU}{dQ} \quad \Rightarrow \theta = \frac{dU}{dM}$$

The table shows various loadings, associated variables, and expressions for elastic energy and displacement. If it is desired to know the displacement of a point on a beam different than where the force is applied, a virtual force Q is applied at the point of interest, and the expression for the moment is determined with all applied loads. For a cantilever beam with a force F applied a distance a from the end, the bending displacement at the end is found from:

$$\begin{aligned} M &= Qx + F \langle x - a \rangle & \frac{dM}{dQ} &= x \\ \Delta &= \int_0^L \frac{(Qx + F \langle x - a \rangle)}{EI} x dx \Bigg|_{Q=0} = \int_a^L \frac{F(x-a)}{EI} x dx = \frac{F(2L^3 - 3aL^2 + a^3)}{6EI} \end{aligned}$$

Here, a virtual force Q is applied and carried through to the integration, then set to zero, the integrand simplified, and then the integral completed. The singularity function is $\langle x - a \rangle = 0$ for $x < a$, so the integral is evaluated from a to L . For displacement at the point of load application, “ Q ” = F . See the curved beam example. For complex loadings, the integral is done in parts.

Energy methods make it simple to include the deflection contribution of shear, which is usually neglected in beams. Why? The advanced methods shown here can either be a refresher to the reader who has seen them before, but perhaps not used them, or as a catalyst to the design engineer.

2. “When a body is elastically deflected by any combination of loads, the deflection at any point and in any direction is equal to the partial derivative of the strain energy, computed with all loads acting, with respect to a load, real or virtual, located at the point of interest and acting in the direction of interest.”

Stiffness: Analytical Methods

- For closed form analysis, singularity functions enable loads to be “turned on” at specific locations

- Create expressions for the moment $M(x)$ as a function of position
- $M(x)$ is used in moment-curvature & energy method calculations

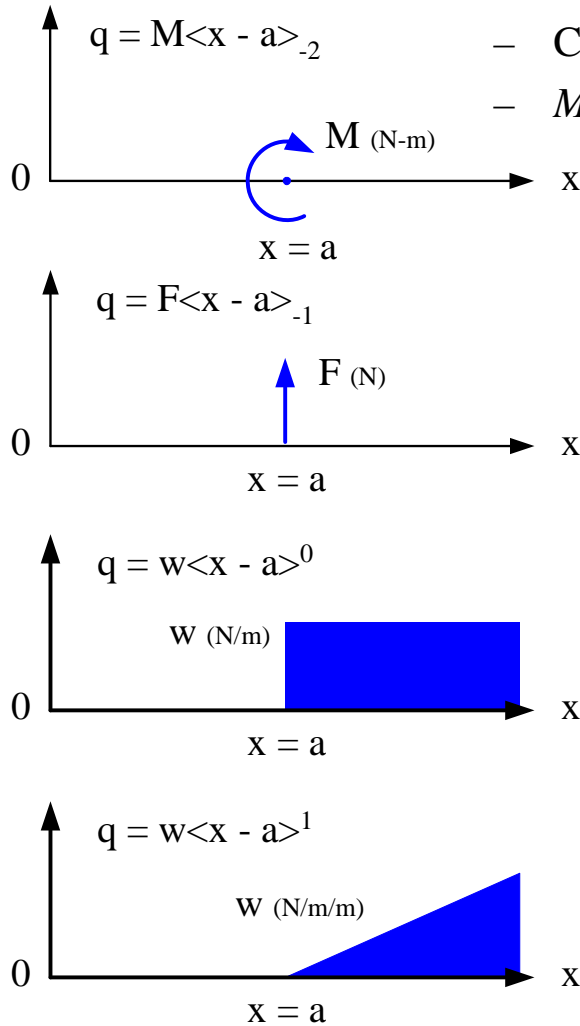

Loading	Variables	Energy	Deflection
Axial	P, E, A	$\int_0^L \frac{P^2}{2EA} ds$	$\int_0^L \frac{F(\partial P/\partial Q)}{EA} ds$
Torsion	Γ, G, I_{polar}	$\int_0^L \frac{\Gamma^2}{2GI_{polar}} ds$	$\int_0^L \frac{\Gamma(\partial \Gamma/\partial Q)}{GI_{polar}} ds$
Transverse Shear (approximate for non-rectangular sections, else $1/2 \Rightarrow 3/5$)	V, G, A	$\int_0^L \frac{V^2}{2GA} ds$	$\int_0^L \frac{V(\partial V/\partial Q)}{GA} ds$
Bending	M, E, I	$\int_0^L \frac{M^2}{2EI} ds$	$\int_0^L \frac{M(\partial M/\partial Q)}{EI} ds$

ds is the distance along the beam (e.g., $ds = dx$ for straight beams, $ds = Rdq$ for curved beam). For determining the slope, differentiate not with respect to a force Q , but an applied moment M (which may also be a virtual applied moment at the point of interest)

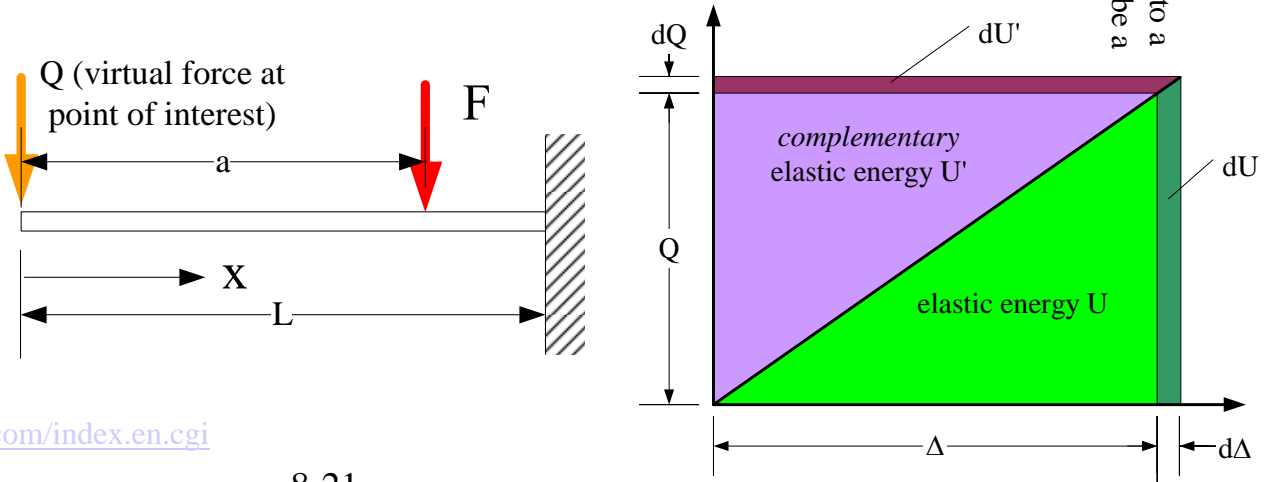

A most useful website is <http://www.integrals.com/index.en.cgi>

Stiffness: *Energy Methods Examples*

Energy methods are particularly useful if the goal is to determine the deflection at one point in a structure. If it is desired to know the shape of the deflected structure, then integration of the moment curvature relation or finite element analysis should be used. Energy methods are also very useful to determine the relative importance of shear and bending contributions, particularly as “beams” become short and beam bending assumptions are no longer clear, as is the case with gear teeth.

To illustrate this, consider a simple cantilever beam loaded at its end by a force F. The vertical deflection of a cantilever beam is given by the well-know expression $FL^3/3EI$, which is obtained from the moment curvature relation or energy methods. Energy methods yield a second shear term also:

$$\delta = \frac{FL^3}{3EI} + \frac{6FL}{5GA}$$

Finite element analysis programs will take shear into account. The graph shows the ratios. The results converge when the length/thickness is about 3-5. Below this level, it is clear that shear deformations are very important. This is further illustration of Saint-Venant’s principle! The 5% error at long lengths is due to FEA effects such as too coarse a mesh (beware, and if this happens, use a finer mesh!). Large deflections also have to be considered in both theory and FEA.

The spreadsheet *Curved_beam.xls* further illustrates the relative contributions of axial, shear, and bending deformations from different load directions as applied to a curved beam shown in the figure. The equations may seem nasty, but with energy methods they are easily derived and then encapsulated into the spreadsheet.

It is important for design engineers to collect information and analysis tools pertaining to the type of design work they most often do. In addition, it is important to check the results of analysis tools against other methods to validate their accuracy! What analysis tools do you find most useful for the design of your contest machines?

Curved_beam.xls To determine deflection of a curved beam				
By Alex Slocum, Last modified 12/29/03 by Alex Slocum				
Enters numbers in BOLD , Results in RED				
Beam				
If round cross-section (enter "yes" or "no")	yes			
Outside diameter, Do (mm)	30			
Inside diameter, Di (mm)	25			
If rectangular cross-section	no			
Outside height, ho (mm)	20			
Outside width, wo (mm)	10			
Inside height, hi (mm)	18			
Inside width, wi (mm)	8			
Radius of curvature, Rr (mm)	100			
Angle, phi (degrees)	90	1.571		
Modulus of elasticity, E (N/mm^2)	200000			
Poisson ratio, v	0.29			
Shear modulus, G (Pa)	77519			
Moment of inertia, I (mm^4)	20586			
Distance farthest fiber to neutral axis, cc (mm)	15			
Cross section area, A	216			
Loading				
Point load, Fx (N)	10			
Point load, Fy (N)	76			
Moment, Mo	22			
x direction displacement (microns)	axial	shear	bending	total
Due to Fx	0.018	0.047	0.865	0.930
Due to Fy	0.000	0.000	9.230	9.230
Due to Mo	0.000	0.000	0.031	0.031
Total	0.018	0.047	10.125	10.190
Y direction displacement (microns)	axial	shear	bending	total
Due to Fx	0.000	0.000	1.214	1.214
Due to Fy	0.138	0.357	14.498	14.992
Due to Mo	0.000	0.000	0.053	0.053
Total	0.138	0.357	15.766	16.260
Slope (milliradians)			Bending	
Due to Fx			0.014	
Due to Fy			0.185	
Due to Mo			0.001	
Total			0.199	

Stiffness: *Energy Methods Examples*

- Energy methods can be used to determine the deflections in a curved beam
 - They can also be used to calculate the relative contributions of axial, shear, and bending; E.g., for a curved beam:

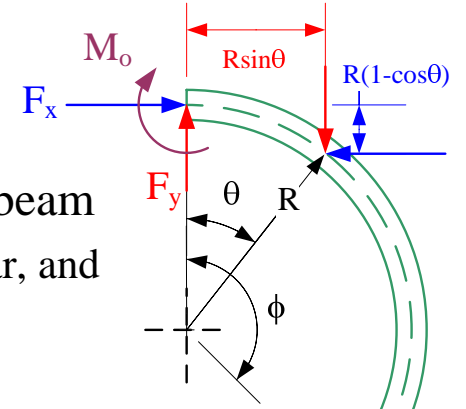

$$\begin{aligned}
 P &= F_x \cos \theta - F_y \sin \theta & V &= F_x \sin \theta + F_y \cos \theta & M &= F_x R(1 - \cos \theta) + F_y R \sin \theta + M_o & ds &= R d\theta \\
 \frac{\partial P}{\partial F_x} &= \cos \theta & \frac{\partial P}{\partial F_y} &= -\sin \theta & \frac{\partial P}{\partial M_o} &= 0 & \frac{\partial V}{\partial F_x} &= \sin \theta & \frac{\partial V}{\partial F_y} &= \cos \theta & \frac{\partial V}{\partial M_o} &= 0 & \frac{\partial M}{\partial F_x} &= R(1 - \cos \theta) & \frac{\partial M}{\partial F_y} &= R \sin \theta & \frac{\partial M}{\partial M_o} &= 1
 \end{aligned}$$

$$\delta_x = \frac{\partial U}{\partial F_x} = \int_0^\theta \frac{F_x \cos^2 \theta - F_y \sin \theta \cos \theta}{EA} R d\theta \Big|_{\text{axial}} + \int_0^\theta \frac{F_x \sin^2 \theta + F_y \cos \theta \sin \theta}{GA} R d\theta \Big|_{\text{shear}} + \int_0^\theta \frac{F_x R^2 (1 - \cos \theta)^2 + F_y R^2 \sin \theta (1 - \cos \theta) + M_o R (1 - \cos \theta)}{EI} R d\theta \Big|_{\text{bending}}$$

$$\delta_x = \frac{R}{EA} \left[F_x \left(\frac{2\phi + \sin 2\phi}{4} \right) - F_y \left(\frac{1 - \cos^2 \phi}{2} \right) \right] \Big|_{\text{axial}} + \frac{R}{GA} \left[F_x \left(\frac{2\phi - \sin 2\phi}{4} \right) + F_y \left(\frac{1 - \cos^2 \phi}{2} \right) \right] \Big|_{\text{shear}} + \frac{1}{EI} \left[R^3 F_x \left(\frac{6\phi - 8 \sin \phi + \sin 2\phi}{4} \right) + R^3 F_y \left(\frac{1 - 2 \cos \phi + \cos^2 \phi}{2} \right) + M_o R^2 (\phi - \sin \phi) \right] \Big|_{\text{bending}}$$

$$\delta_y = \frac{\partial U}{\partial F_y} = \int_0^\theta \frac{-F_x \cos \theta \sin \theta + F_y \sin^2 \theta}{EA} R d\theta \Big|_{\text{axial}} + \int_0^\theta \frac{F_x \cos \theta \sin \theta + F_y \cos^2 \theta}{GA} R d\theta \Big|_{\text{shear}} + \int_0^\theta \frac{F_x R^2 \sin \theta (1 - \cos \theta) + F_y R^2 \sin^2 \theta + M_o R \sin \theta}{EI} R d\theta \Big|_{\text{bending}}$$

$$\delta_y = \frac{R}{EA} \left[-F_x \left(\frac{1 - \cos^2 \phi}{2} \right) + F_y \left(\frac{2\phi - \sin 2\phi}{4} \right) \right] \Big|_{\text{axial}} + \frac{R}{GA} \left[F_x \left(\frac{1 - \cos^2 \phi}{2} \right) + F_y \left(\frac{2\phi + \sin 2\phi}{4} \right) \right] \Big|_{\text{shear}} + \frac{1}{EI} \left[R^3 F_x \left(\frac{1 - 2 \cos \phi + \cos^2 \phi}{2} \right) + R^3 F_y \left(\frac{2\phi - \sin 2\phi}{4} \right) + M_o R^2 (1 - \cos \phi) \right] \Big|_{\text{bending}}$$

$$\theta = \frac{\partial U}{\partial M_o} = \int_0^\theta \frac{F_x R (1 - \cos \theta) + F_y R \sin \theta + M_o}{EI} R d\theta \Big|_{\text{bending}}$$

$$\theta = \frac{1}{EI} \left[R^2 F_x (\phi - \sin \phi) + R^2 F_y (1 - \cos \phi) + M_o R \phi \right] \Big|_{\text{bending}}$$

See Beam_curved.xls

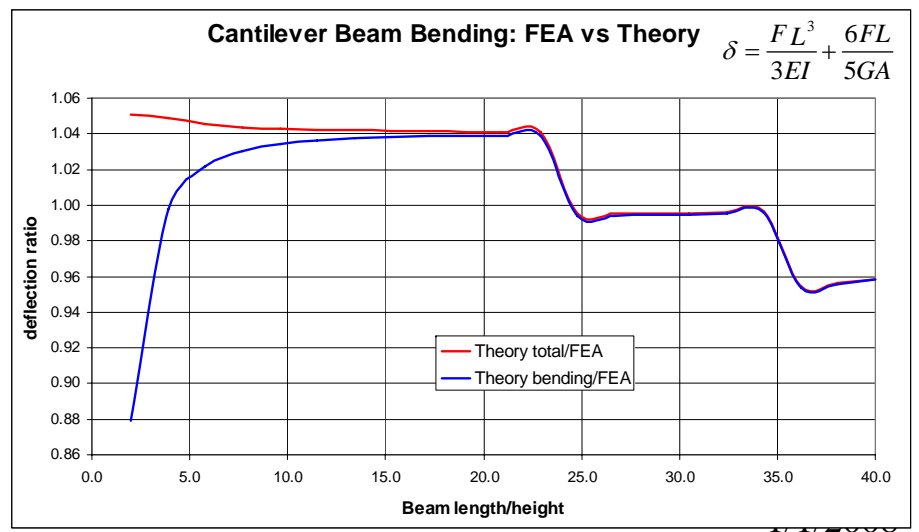
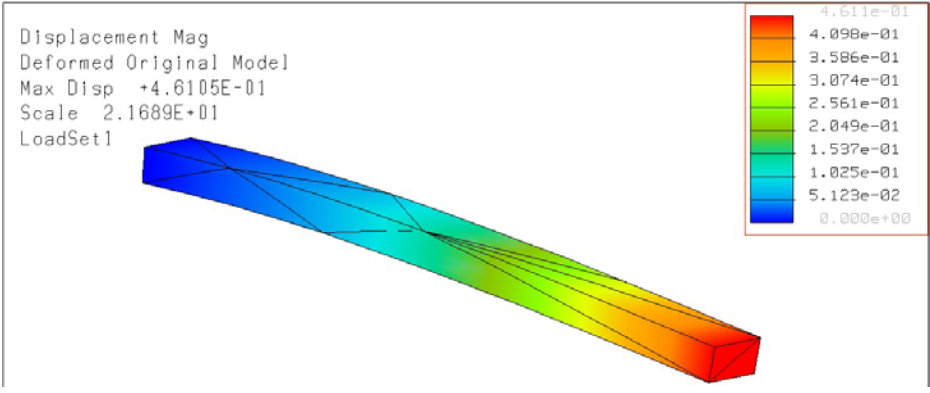

Stiffness: *Finite Element Analysis*

Finite Element Analysis is a powerful tool that essentially divides a complex structure up into many small elements, where for each the stresses and deformations can be solved for using known equations of elasticity. Because the boundaries of each element in contact with another element must have equal and opposite forces and equal deflections, a large array of equations can be generated and solved by computer to determine the forces and deflections on all the elements. A critical issue is the constraints on the exterior elements that are meant to model the connection of the part to the world. For example, a cantilever beam has all the faces of elements at one end constrained to not have any deflections. But what about a simply supported beam?

There are some types of elements, plates and shells that are two dimensional yet are assigned a thickness. These 2D elements can have an edge constrained to be simply supported (no linear displacement) or supported so there is no linear or angular displacement. Most design engineers creating new designs use a solid modelling system, and the solid modeler is often linked directly to an FEA program. Herein lies the challenge, because some (not all) FEA programs take a solid model and break it up into solid elements, where their solid elements can only be constrained along a surface which causes a moment constraint (no linear or angular translations) to always be imposed. The moment constraint does not always capture the intent of the designer and can cause a structure's stiffness to be greatly over predicted. Fortunately, as shown, some FEA programs do allow a solid's edge to be displacement but not rotation constrained.

If an FEA program does not allow the edge of a solid to be simply constrained, thin solid flexural elements can be added as shown. The table shows the size of a uniformly loaded beam modeled and the deflections predicted by theory and by FEA with several different boundary conditions. Note the Saint-Venant effect: the flexure should be an order of magnitude thinner than the beam it supports, and the flexure length should be an order of magnitude greater than its thickness. The same type of constraint issue is addressed for bolted joint connections on page Page 9-12. As with any tool, FEA can be a great asset and time saver, but used improperly, a design engineer might think they have a great design, and then when its built and too late and too expensive to change things, the design is found to not meet specifications. Attention to details and really understanding the FUNdaMENTALS is soooo important!

Total uniform load, W (N)	100	
Length, L (mm)	200	
Width, b (mm)	20	
Thickness, t (mm)	10	
Modulus, E	200028	
I (mm ⁴)	1667	
	deflection at center (mm)	
	simply supported	fixed-fixed
Theory	0.03125	0.00625
FEA (with thin flexure support)	0.03096	0.00635
FEA (PRO/Mechanica with edge constraint applied to solid)	0.03162	0.00634
Flexure length/thickness	FEA deflection	
20	0.03096	
10	0.02890	
5	0.02062	

There are many other FEA tricks that can be done to enable you to rapidly and simply use a solid model created for design and part detailing to then be easily used in FEA. For example, for bearings see page 10-23. The key is to always just think FUNdaMENTALLY what is physically happening and then adjust/add features and properties accordingly.

Review the solid model for your machine and isolate critical elements such as a module that uses gears. How will gear tooth separation forces under maximum torque transmission cause deflections? Are these deflections less than 1/5th of the gear tooth height? How can you use theoretical predictions or FEA to model the system and make this determination? It is important to be able to do the detailed analysis of a critical module and document your process, the results, and any changes that the results lead you to make. This type of design study will be what you will typically be called upon to do in your professional life. If you become a manager, you will want to require your engineers to do this type of study, but unless you do it several times yourself first, you will not really be able to intelligently review what you want your engineers to do. Having this type of study in your portfolio for job interviews is also a powerful salary and position responsibility enhancing catalyst!

Stiffness: *Finite Element Analysis*

- Solid models that directly feed into FEA programs must be used carefully
 - Some FEA programs allow the user to select an edge as a simply supported constraint (moments not constrained).\
 - Some FEA programs import solid models as solid elements that can only be constrained at their faces, not along an edge, and hence zero slope is enforced
 - To model a simply supported connection, create a long thin solid element
 - » A flexural bearing support: use Saint-Venant where the length is 20x the thickness

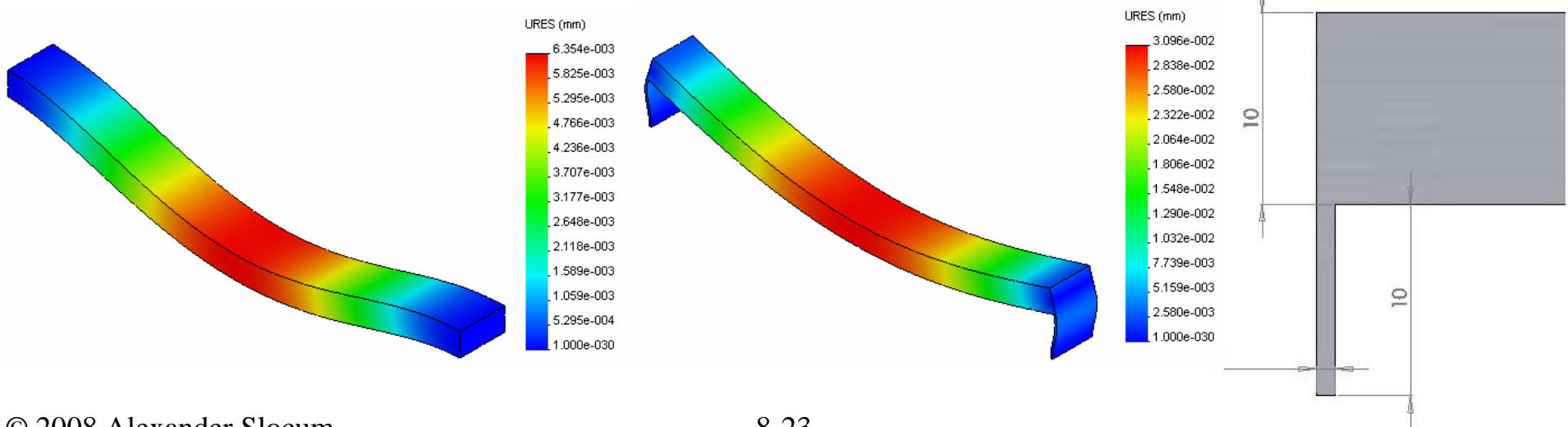
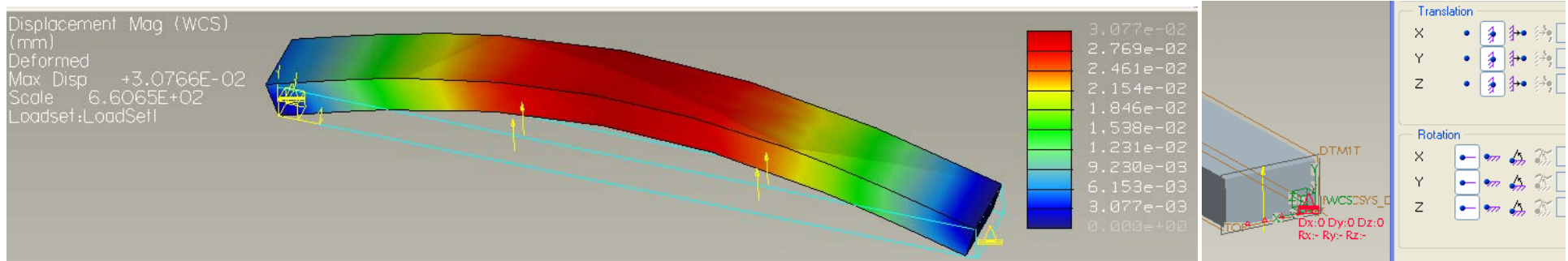

Stiffness: *Plates*

The most important plate analysis parameter is the plate constant D which is a function of the material's modulus of elasticity E , the poisson ration ν , and the plate thickness t :

$$D = \frac{Et^3}{12(1-\nu^2)}$$

As with beams, the stiffness, both displacement and slope, will be proportional to the thickness cubed of the plate, and the stresses will be proportional to the thickness squared. Furthermore, as with all applications of simple elastic deflection theory, it is assumed that the thickness is small compared to the length of a beam or the diameter of a plate. How much is "less"? Saint - Venant says "less" is a factor of about 5.

The manner in which the edge of the plate is restrained also has a huge effect on stiffness. A plate with a simply supported boundary, one that does not support a moment may be 4-5 times more compliant than a plate whose boundary is fixed. However, making a boundary itself stiff enough to actually create a fixed boundary support is difficult. One essentially has to invoke Saint-Venant and make the thickness of the supporting structure 3-5 times that of the plate. In reality, this is done using orthogonal plates whose thickness may also be stiffened with orthogonal plates. The use of raised features on plates is also a common method for stiffening plates without greatly increasing the weight. Similarly, the edge of a plate can be folded over to help increase its stiffness.

Faced with a plate problem, it may be tempting to reach for a handbook to look up an equation, much the way engineers often do for bending beams. However, there are innumerable complex plate equations, and the constants to be evaluated can cause one to lose site of the insights that might otherwise be gained. In addition, because plates are large surfaces that are likely to have other things attached to them, finite element analysis is often the primary analysis tool. Still, for basic configurations, simple closed-form equations exist and can provide important insight into the behavior of a plate. This helps with the creation of initial concepts that can then be analyzed with finite element analysis.

Some of the simpler and more common and useful configurations are shown, along with the equations used to create the spreadsheets *Plate_Circular_Central.xls*, *Plate_Circular_Uniform.xls* and *Plate_Rectangular.xls*. The plots of deflection as a function of radius illustrate the Abbe error risks faced by designers who anchor precision components to plates: The slope angle on the deflected plate can cause displacements that can cause components to bind.

There are several countermeasures to the risk of plate deflection-induced slope angles causing component binding. The first is the brute force method of increasing the plate thickness. Because the stiffness increases with the cube of the thickness, this is actually not such a brute-force method, and often the problem can thus be easily addressed if the design engineer thinks of the risk before the machine is built! In particular, as discussed on page 8-29, laminates can be particularly effective. For design contests, metal plates bonded to either side of a foam or wood core can create a very stiff plate.

The second countermeasure involves mounting the components so their interfaces to other components can accommodate displacement, caused by sine errors (slope x distance) and misalignment (slope). A classic example is in an automobile where the driveshaft must transmit power from the precision mechanism of the transmission to the precision mechanism of the differential. Torque must be transmitted, but accommodations must be made for angular misalignments and axial displacements as the car frame deforms under load. To accommodate these motions, each end of the drive shaft has a two-angular-degree-of-freedom joint, such as a universal joint. In addition, a spline allows one part of the drive shaft to slide in and out of the other, so its length can change, which still maintains torque transferring ability. See page 5-27 for a quick refresher on how such a coupling can easily be manufactured.

[What kinds of plates do you have in your machine? What are the risks of plate deformation on machine performance? Is there an appropriate analysis that can be performed with simple spreadsheets? Or is it less costly \(time is money\) to make a simple model and load it? Perhaps the most difficult task is estimating the loads to which the plate will be subjected.](#)

Stiffness: Plates

$$r_o' = \sqrt{1.6r_o^2 + t^2} - 0.675t \quad \text{if } r_o < 0.5t$$

$$M_r = \frac{W}{4\pi} \left[(1+\nu) \ln \frac{a}{r} - 1 + \frac{(1-\nu)r_o'^2}{4r^2} \right]$$

$$M_t = \frac{W}{4\pi} \left[(1+\nu) \ln \frac{a}{r} - \nu + \frac{\nu(1-\nu)r_o'^2}{4r^2} \right]$$

$$\theta = \frac{Wr}{4\pi D} \ln \frac{a}{r}$$

$$\delta = \frac{-W}{16\pi D} \left(a^2 - r^2 \left(1 + 2 \ln \frac{a}{r} \right) \right)$$

$$M_{r \max @ r=0} = \frac{W}{4\pi} (1+\nu) \ln \frac{a}{r_o} \quad M_{r \min @ r=a} = \frac{-W}{4\pi}$$

$$M_{t \max @ r=0} = \frac{W}{4\pi} (1+\nu) \ln \frac{a}{r_o} \quad M_{t \min @ r=a} = \frac{-\nu W}{4\pi}$$

$$\theta_{\max @ r=0.368a} = 0.0293 \frac{Wa}{D}$$

$$\delta_{\max @ r=0} = \frac{-Wa^2}{16\pi D}$$

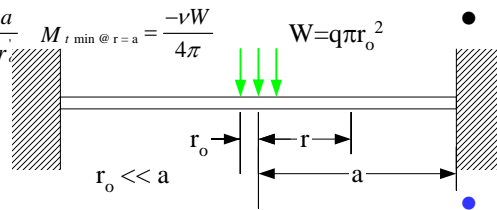

A few simple loading cases give insight into the nature of stresses & deformations in plates

Check out the many different spreadsheets!

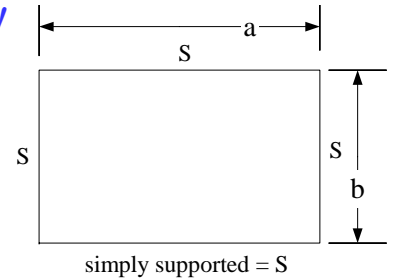

$$r_o' = \sqrt{1.6r_o^2 + t^2} - 0.675t \quad \text{if } r_o < 0.5t$$

$$M_r = \frac{W}{16\pi} \left[4(1+\nu) \ln \frac{a}{r} + (1-\nu) \left(\frac{a^2 - r^2}{a^2} \right) \frac{r_o'^2}{r^2} \right]$$

$$M_t = \frac{W}{16\pi} \left[4(1+\nu) \ln \frac{a}{r} + (1-\nu) \left(4 - \frac{r_o'^2}{r^2} \right) \right]$$

$$\theta = \frac{Wr}{4\pi D} \left(\frac{1}{1+\nu} + \ln \frac{a}{r} \right)$$

$$\delta = \frac{-W}{16\pi D} \left(\frac{3+\nu}{1+\nu} (a^2 - r^2) - 2r^2 \ln \frac{a}{r} \right)$$

$$M_{r \max @ r=0} = \frac{W}{4\pi} \left[4(1+\nu) \ln \frac{a}{r_o} + 1 \right]$$

$$M_{t \max @ r=0} = \frac{W}{4\pi} \left[4(1+\nu) \ln \frac{a}{r_o} + 1 \right]$$

$$\theta_{\max @ r=a} = \frac{Wa}{4\pi D(1+\nu)}$$

$$\delta_{\max @ r=0} = \frac{-Wa^2(3+\nu)}{16\pi D(1+\nu)}$$

Circular plates with support around entire outer boundary

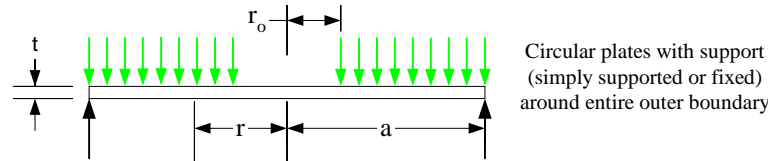
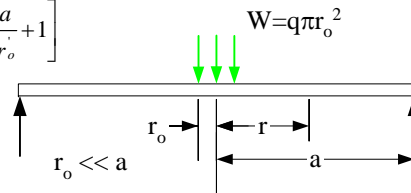

Circular plates with support (simply supported or fixed) around entire outer boundary

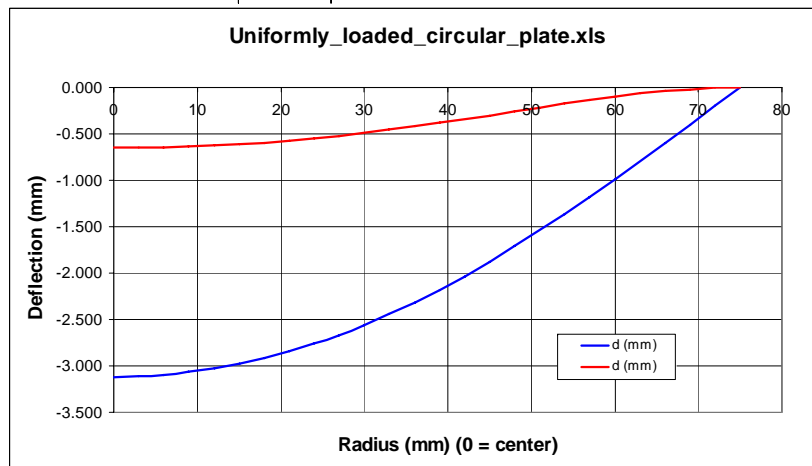

$$D = \frac{Et^3}{12(1-\nu^2)}$$

Plate Rectangular.xls	
To determine deflection of a rectangular plate	
From Roark & Young, Formulas for Stress and Strain, 5th edition, pag	
By Alex Slocum, Last modified 1/1/04 by Alex Slocum	
Enters numbers in BOLD , Results in RED	
Plate	
length a (mm)	300
width, b (mm)	200
thickness, t (mm)	1.5
Modulus of elasticity, E (N/mm ²)	68947.6
Poisson ratio, ν	0.3
Total area	60000
a/b, aob	1.50
Loading	
uniform loading pressure over entire plate, q (N/mm ²)	0.00017
total load applied to the plate, W (N)	10
uniform over small concentric circle of r _o , q _o (N/mm ²)	10
load application radius, r _o (mm)	2
total load applied to center of plate, W _o (N)	126
Simply supported outer boundary:	
Distributed load:	
Center displacement, d _c (mm)	-0.096
Bending stress at center (N/mm ²)	1
Reaction load at center of long side (N/mm)	0
Centrally applied concentrated load:	
Center displacement, f _{dc} (mm)	-3.621
Bending stress at center (N/mm ²)	190

Stiffness: Plates Examples

Engineering estimation is an important skill to develop. This includes being able to use as simple a model as possible to obtain an initial estimate for initial concept evaluation. For example, is a single aluminum plate stiff enough for a robot base? Assume we have an aluminum plate that serves as the main chassis. The plate supports the wheels and the bearings located at its corners. The dimensions of the plate, with the outer wheel support bearings' centers at the plate corners, are 200 mm x 300 mm x 1.5 mm, and it is uniformly loaded with 10 N. Can the wheels of a 2WD car with a solid axle essentially be mounted at the corners and all the rest of the robot built on top? Is this a good design? Why or why not for many reasons?

Is this really a plate and do we need plate theory? Is there a simple model we can use, or do we have to resort to finite element analysis? Can we model the system as a beam? The latter would be the simplest and fastest option. Spreadsheets *Plate_Rectangular.xls* and *Beam_Simply_supported.xls* were used along with finite element analysis. The images show the FEA results which only give the deflections. To estimate the slope at a point, one can locally make a linear approximation. 2/3rds of the center deflection divided by 1/3rd of the length makes a reasonable approximation:

	Center deflection (mm)	Slope (mrad) at corner	
		300mm side	200 mm side
Simply supported beam theory	0.906, 0.179	9.66	2.87
Simply supported edges theory	0.096	0.64	0.96
Simply supported edges FEA model	0.043	0.29	0.43
Four corners supported FEA model	0.945, .030	6.30	0.30

Note that the center deflections reported for the simply supported beam model assumed first that a 300 mm beam is simply supported, and that the beam has a width of 200 mm, and hence the distributed loading is 0.033 N/mm. For the second case of the slope along the 200 mm edge, a 200 mm long beam is assumed with a distributed loading of 0.05 N/mm. In which direction is the slope most important, along the 200 or 300 mm length of the plate? The axis of motion of the vehicle should be along the 300 mm direction. Why? The load was assumed to be only 10 N distributed over the entire plate. What might be the real load, and what might be dynamic effects? Plan for about 50 N, and then there would be about 2 mrad of angular error on the 200 mm side.

Bearing_shaft_allowable_misalign.xls shows that the thin aluminum sheet should actually be OK in this case:

bearing_shaft_allowable_misalign.xls		
To determine bearing clearance when shaft is angled		
By Alex Slocum, Last modified 1/4/2004 by Alex Slocum		
Enters numbers in BOLD , Results in RED		
Bearing length, L (mm)	5	
Bearing inner diameter, d (mm)	6	
Shaft diameter, Ds (mm)	5.9	
Allowable small misalignment angle, α (milli radians, degrees)	19.5	1.120

What is learned from this exercise? The simply supported beam model provides a good conservative estimate, when compared to the baseline “accurate” four-corners-supported FEA model. It should also be seen that initial design calculations can be quickly done to greatly reduce risk. If the calculations had indicated there might be a problem, then it would have been easy to fix using a countermeasure. For example, the edges of the sheet metal can be folded to create a “pan” that makes the structure act more like a simply supported plate. In this case, the simply supported plate theory would be a very good simple model for the system. However, without the corners connected, the edges can still flare outward. Note the proper FEA constraints of points near the holes made to support wheel-shaft bearings: PNT0: XYZ, PNT1:YZ, PNT2&3: Z. Why are they constrained like this instead of just constraining all the degrees of freedom (XYZ) at each of the points? Why are there triangular cutouts in the sheet metal? Is it better to try and fold the corners over so they can be riveted, or to just make 4 angle brackets which then rivet the corners together? How much stiffer is this latter fixed-corner design?

3D folded sheet metal structures can be easily created in a solid modeling program, and then unbent flat so the parts can easily be cut, for example by an OMAX Abrasive Waterjet Machining Center™. This can save a lot of time, but it requires analysis, design, and manufacturing to be done with care and balance.

How would you design and analyze a manufacturable folded sheet metal structure to form the basis of your machine structure? Turn on your solid modeling program and give it a try!

Stiffness: *Plate Examples*

- Al plate 200 x 300 x 1.5mm uniformly loaded with 10N

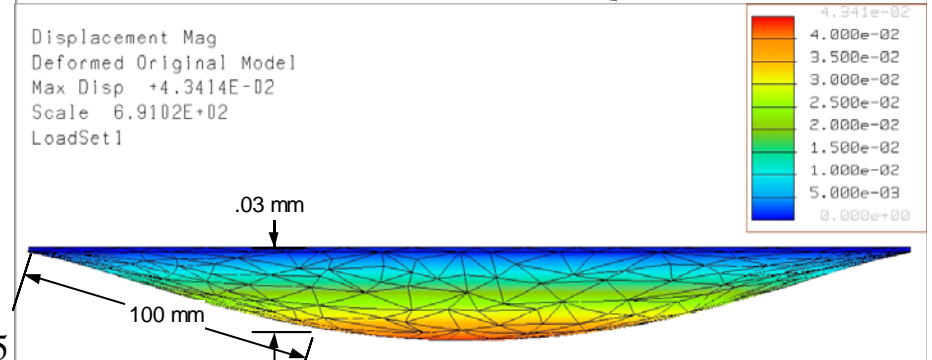
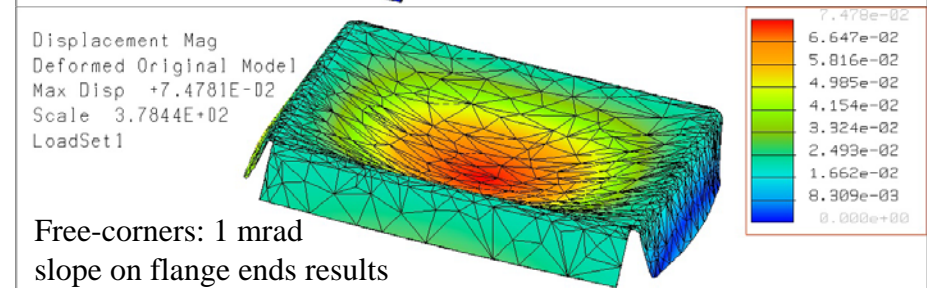
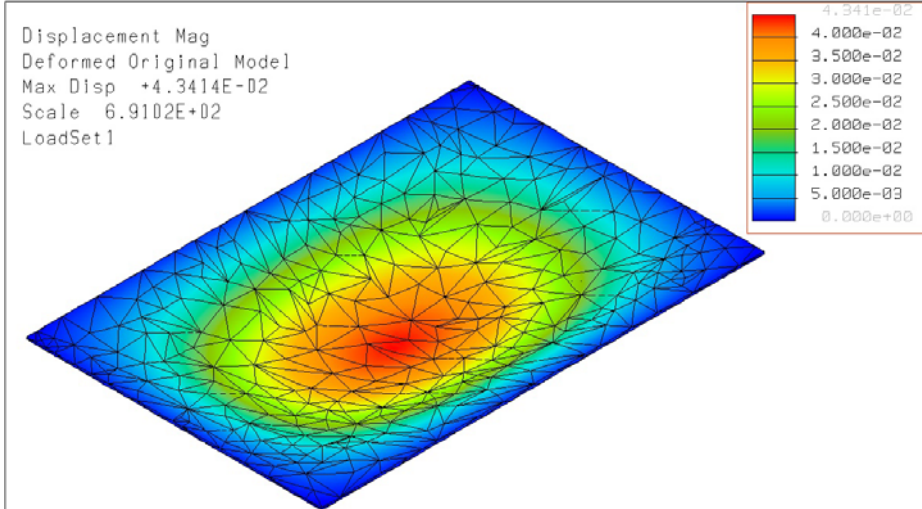
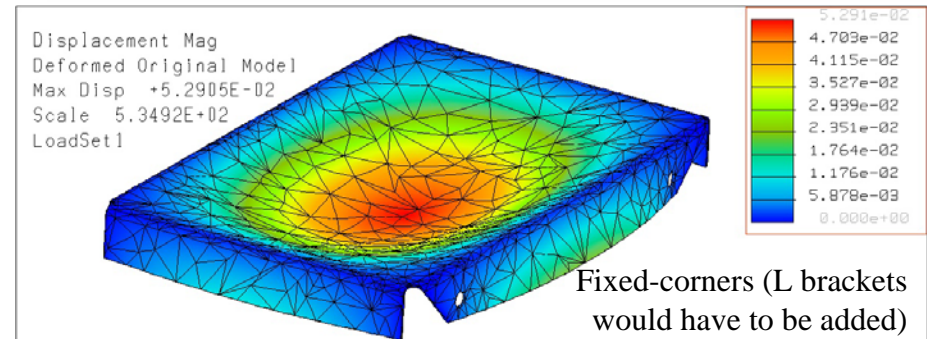
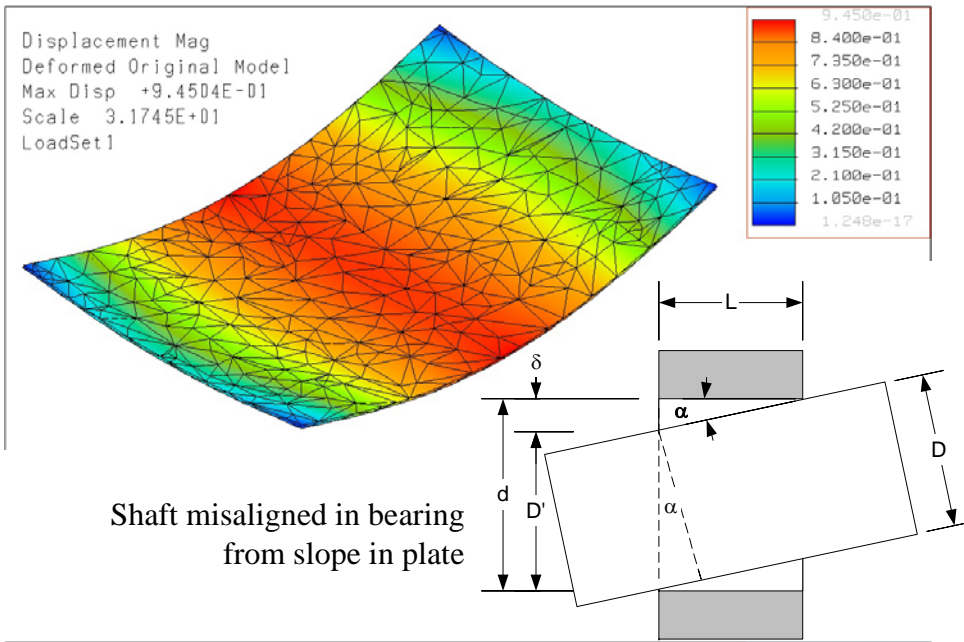
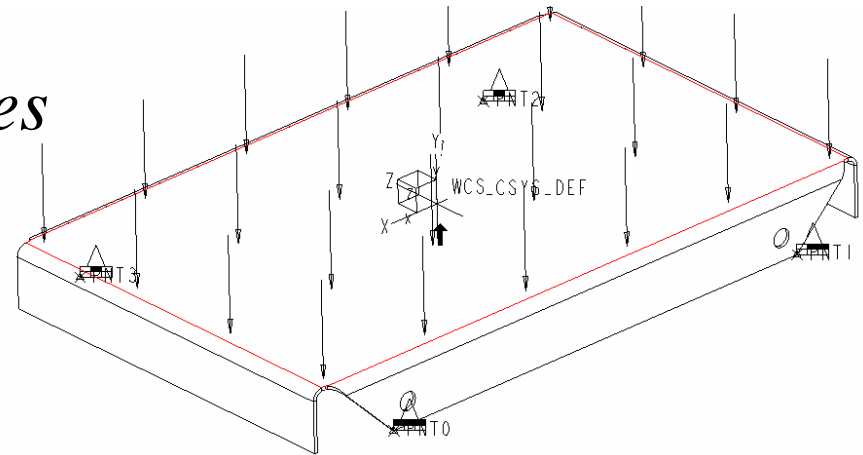

Strength

Many machines are designed for stiffness to ensure that their machine elements maintain proper clearances, and when designing for stiffness, strength is often not an issue. However, many designs are strength-based; they are not as much concerned with deflection as they are with not breaking! The nice thing is that the analysis process is much the same, because in both cases, the bending moment must be determined. Page 8-18 showed the properties of various cross sections and the bending moments for several different common mountings of beams. The stress in a bending beam is then just a function of the bending moment:

$$\sigma(y) = \frac{M}{I/y} = \frac{My}{I} \quad \sigma_{\max} = \frac{Mc}{I}$$

The stress in plates is also dependent on the moment, but the moment in a plate is defined as the moment per unit length, and hence has units of force. The stress in a plate is then given by

$$\sigma = \frac{6M}{t^2}$$

Tensile or compression stresses from uniaxial tension or compressive force F is simply a function of the minimum cross sectional area A :

$$\sigma = \frac{F}{A}$$

For simple circular sections of outer diameter D_o and inner diameter D_i , the torsional stress created by a torque Γ on the shaft is:

$$\tau = \frac{\Gamma r}{I_{polar}} \Rightarrow \frac{16\Gamma D_o}{\pi(D_o^2 - D_i^2)}$$

Multiple loads are often applied to a structure. For linear elastic materials, which is most often the case in the design of products and machines,

the fundamental principle of *Superposition* can be applied. This means that the stresses from many different load states can be individually assessed, and then combined. The stresses along a common axis simply add. The sums of stresses along and about different axes can be combined into a total state of equivalent stress, which can then be compared to the yield stress for the material, using the von Mises equivalent stress criteria. The von Mises criteria combines axial stresses (bending, tension, compression) with shear stresses (shear, torsion). The product of the von Mises stress and various loading factors should then be less than the yield strength of the material:

$$\sigma_{yield} \geq k_s \sqrt{\left((\sigma_x - \sigma_y)^2 + (\sigma_x - \sigma_z)^2 + (\sigma_y - \sigma_z)^2 \right) / 2 + 3\tau_{xy}^2 + 3\tau_{xz}^2 + 3\tau_{yz}^2}$$

$$k_s = k_{SF} \times k_{LF} \times k_{EF} \times k_{SCF}$$

- K_{SF} is the *Safety Factor* associated with uncertainty in what are the magnitudes of the actual loads on the system. A typical value is $K_{SF} = 2$. If the uncertainty is higher, the loads need to be better understood.
- K_{LF} is the *Load Factor* associated with the level of severity of service. When the structure is subject to severe dynamic impact, K_{LF} may be as high as 3; however, this should only be used for initial feasibility studies. Any structure subject to large impacts will require careful simulation before building, e.g., with finite element analysis. Else $K_{LF} = 1$.
- K_{EF} is the *Environmental Factor* associated with the harshness of the environment. If the environment is hot, humid, or corrosive, even though an appropriate material must be used, an additional factor may be added to guard against uncertainty. It may also be as high as 3. Else $K_{EF} = 1$.
- K_{SCF} is the *Stress Concentration Factor* which is a very real and predictable effect associated with sharp corners and other features. It can be as high as 3, but with good design is typically less than 2 (see page 8-27).

How stressed are you and your machine at this point? For a robot design contest, the safety factor might be 2, the stress concentration 1.5, and other factors 1. The smallest part that breaks can doom a machine to fail. One gear tooth failing can bring a bulldozer to a halt or down a plane or helicopter. Follow each load path through your machine's structural loop and evaluate the risk and the effect of each element if it fails.

Strength

- **Stress=Moment*distance of farthest fiber from Neutral axis/Moment of Inertia:**

$$\sigma = \frac{Mc}{I}$$

- Stress ratio = Applied stress / Maximum allowable stress

- **The *parallel axis theorem* can be used to evaluate any cross section's inertia:**

- Most important: The parallel axis theorem tells us that a section stiffens with the square of the distance from the neutral axis!
 - E.g., when designing a laminate (1/16" AL sheet separated by wood core), double the core thickness and quadruple the panel stiffness!

- **Torsional shear stress=Torque*radius/polar moment of inertia**

- **Stresses caused by multiple loads can be combined into an equivalent stress by the von Mises equivalent stress formula:**

$$\sigma_{equivalent} = \sqrt{\frac{(\sigma_x - \sigma_y)^2 + (\sigma_x - \sigma_z)^2 + (\sigma_y - \sigma_z)^2}{2} + 3\tau_{xy}^2 + 3\tau_{xz}^2 + 3\tau_{yz}^2}$$

Funny image found on www, photographer not credited, would like to, email slocum@mit.edu



Ten 80 lb bags of concrete

OK, what's the ratio of the stress ratio in the bar to the stress ratio in the knees?

8-26

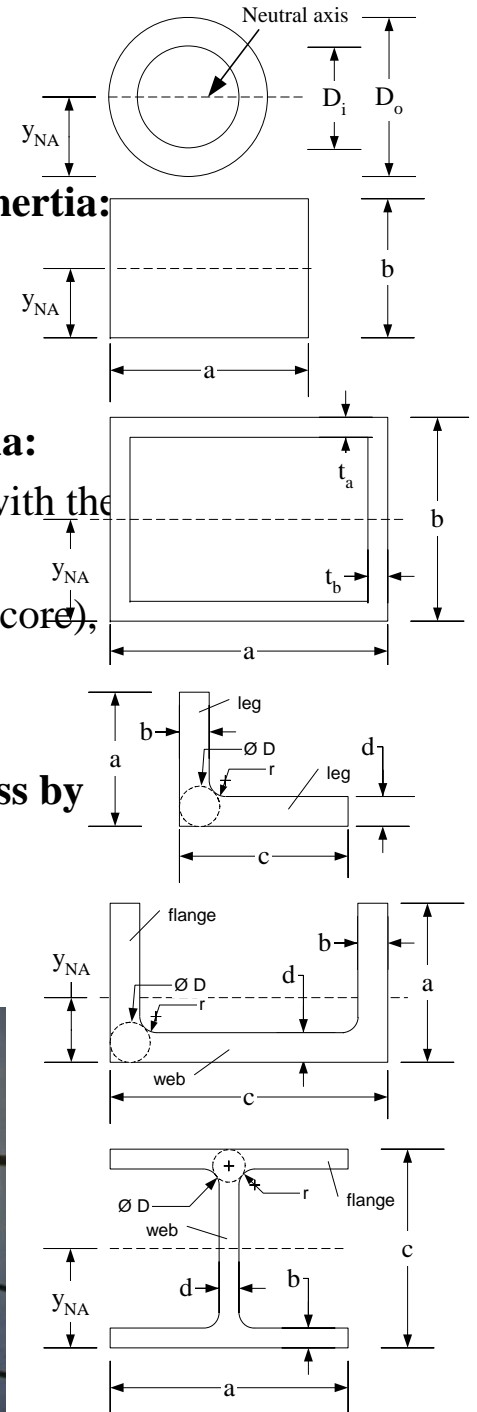

Strength: 1st Order Analysis

As described in detail in Topic 1, *The MIT and the Pendulum* was a contest where each contestant had a 2.5 m long 75 mm square plastic tube with 3 mm wall thickness. The tube was filled with street-hockey-balls and supported by a pivot through its center. Some students wanted to be able to clamp onto the tube and use a drive wheel to drive up the tube to engage the support shaft and start the pendulum rotating. How hard could they preload the drive wheel without breaking the tube? If they broke the tube, they would lose in a BIG way! The students were advised to do appropriate analysis, because trial and error could result in breaking the tube and failing the course!

With modern solid modeling and finite element analysis programs, it seems to be a straightforward task to model an existing system and apply a load to determine its effects on the system. In this case, how long of a beam segment should be included in the model? One could include the entire beam, and although this adds a few seconds of processor time for this simple case, in more complex systems, it could add minutes or more. When FEA is used for design studies, where a design parameter is varied over a wide range so the design program can then plot the effect of the varying parameter on the desired factor, these minutes rapidly add up.

Saint-Venant comes to the rescue once again. In this case, the characteristic dimension is the width of the beam, so the segment modeled should be 3-5 times as long as the width. The FEA results show that after about 3 times the width on either side of the force, the model has fully converged:

By Finite Element Analysis		
Beam Width	Von Mises Stress	Deflection
(mm)	(N/mm ²)	(mm)
75	28	2.0
150	29	1.5
225	27	1.4
300	29	1.4
375	26	1.4
450	25	1.4

What if the load were applied over a fixed length instead of at a point? In that case, the length of the beam should extend 3 characteristic dimensions on either side of the limits of the load.

The FEA model used here also took advantage of symmetry. Only one-quarter of the beam was modeled, and the faces along the cuts were constrained to only deform normal to the beam surface which they intersected. Could a one-eighth model have been used in this case? (Yes, but the full length was kept here for better visualization, as was the full-section model).

Is there a simple beam model that could have been used? A simply supported beam model would have a beam of length equal to the width of the beam section, and length equal to? A point load is applied to the real structure, but a simply supported beam model assumes the force is applied across the entire width of a beam. Can Saint-Venant help? It would appear that the beam length should be about 5 times the width in order for the maximum predicted deflection to be on the order of the actual deflection. However, the predicted stress is far from the actual stress. Here is a case where it is inappropriate to apply a simple model because it results in far too conservative a result.

By Simply Supported Beam Model		
Beam Width	Von Mises Stress	Deflection
(mm)	(N/mm ²)	(mm)
75	1.7	16.7
150	0.9	8.3
225	0.6	5.6
300	0.4	4.2
375	0.3	3.3
450	0.3	2.8

This type of analysis is called *boundary analysis*, where upper and lower limits (bounds) or extremes are considered. What critical high-stress situations might exist in your machine and how might you model upper and lower bounds? If there is risk and uncertainty, should you not invest the time in a finite element model, or a real physical model that you can test? A Bench-Level-Experiment, real or virtual, now can prevent much agony later.

Strength: *1st Order Analysis*

- Square tube with point loads (from wheels) on two opposite sides

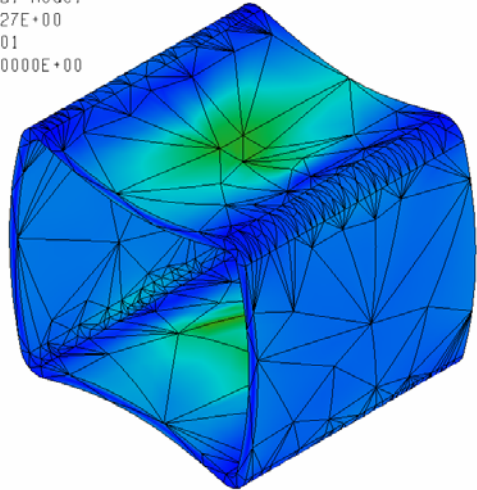
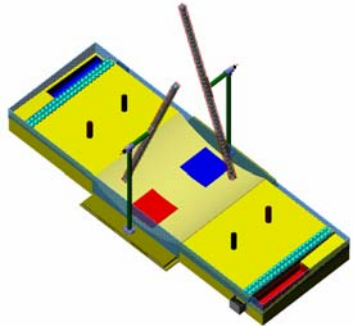
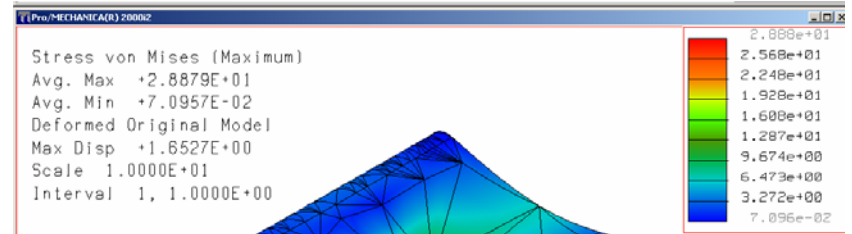
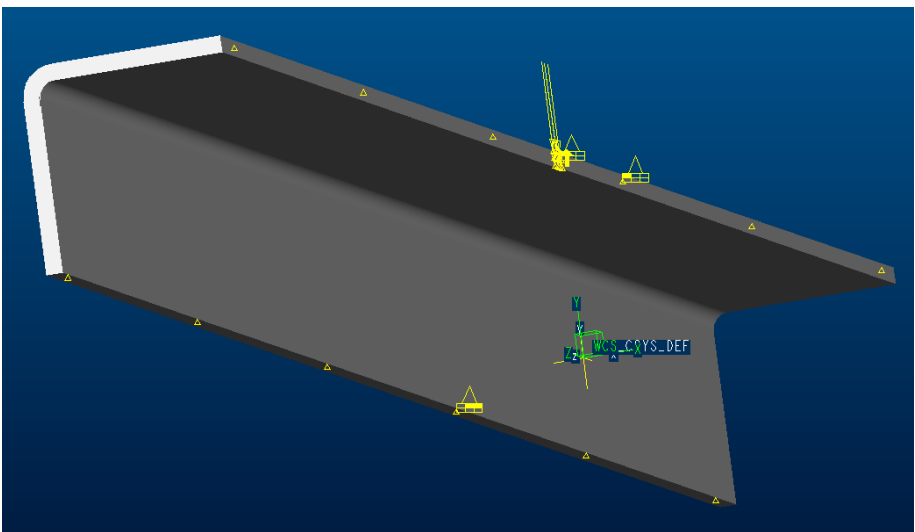
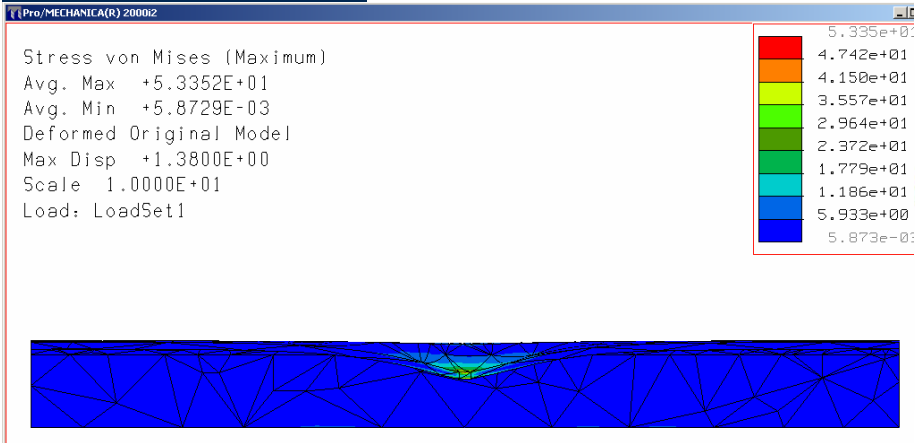
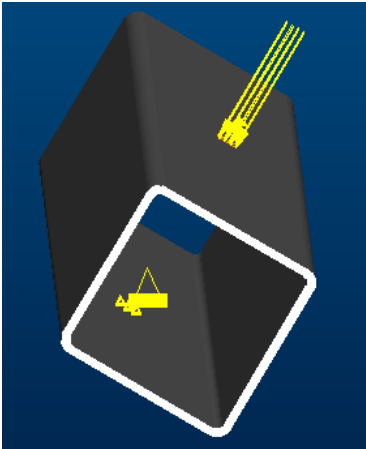

H

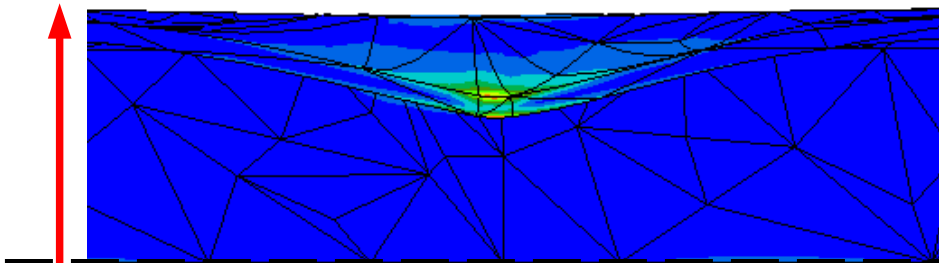

H

Model plane of symmetry

Yes, yes, yes, for all you FEA avocados out there, only a 1/8 models with zero slope constraints at the planes of symmetry is actually needed

Strength: Life, Fatigue and Stress Concentration

To give structures long life, they must be designed not according to just the *yield strength* of the material, but to the *endurance strength* of the material. On page 8-5 the yield and tensile (ultimate) stress levels for a material were defined for one loading cycle. But how many times can the stress be applied, removed, and then reapplied before the structure *fatigues*? The *endurance limit* is how many stress cycles can be applied before failure, and it depends on the type of material used. Materials referred to as Type 1 materials herein, such as ferrous alloys, have an *endurance limit* where if the stress is kept below this limit, life will be “infinite”. Materials referred to as Type 2 materials herein, such as aluminum alloys, have no endurance limit, which means that even if only 1% of the ultimate tensile stress is applied, with enough cycles, eventually, they will fail. Materials such as plastics (or metals at high temperatures) will *creep* when subject to continual high stress.

To conservatively design a structure from Type 1 materials to have “infinite life”, the equivalent alternating stress, calculated for example using the von Mises criteria including the stress factors, (see page 8-25) should be less than one-half the ultimate tensile stress for the material:

$$\frac{\sigma_{tensile}}{2} \geq k_s \sqrt{\left((\sigma_x - \sigma_y)^2 + (\sigma_x - \sigma_z)^2 + (\sigma_y - \sigma_z)^2 \right) / 2 + 3\tau_{xy}^2 + 3\tau_{xz}^2 + 3\tau_{yz}^2}$$

$$k_s = k_{SF} \times k_{LF} \times k_{EF} \times k_{SCF}$$

Will this lead to a too conservative design? This is where attention to detail and knowledge of statistics and the environment in which the machine is used become the cornerstones of engineering design. Anyone can design given infinite resources, but only the best can design with less! Structures typically also have a continuous or mean applied stress in addition to cyclic (alternating) stresses. The *Goodman diagram* is a means to determine the relative allowable mean and alternating stress levels. For a typical Type 1 material, the allowable mean S_{mx} and alternating stresses S_{ax} are related in terms of the ultimate strength and the endurance limit by:

$$S_{ax} = \frac{-S_{en}}{S_u} S_{mx} + S_{en}$$

When most people see a crack in something, they know from experience that the object has been weakened. It is not just that the crack has reduced the cross-section, the crack seems to amplify stresses and make the object break more easily. But how sharp must the crack be to create this effect? This is the heart of the matter with stress concentration factors. Stress concentrations can cause high local stresses and small fatigue cracks. These cracks have very sharp tips, far sharper than the manufactured feature that gave rise to their formation. As a result, the cracks start to grow, and failure can soon thereafter occur. The study of how cracks form and grow is called *fracture mechanics*, and it is a critical engineering function in many industries: Every company wants to reduce costs, and reducing structural weight typically also reduces cost. However, too much weight reduction can lead to too small sections which then fatigue and fail. Reciprocity tells us that putting notches into structures to create breakaway points can also sometimes be a good idea!

Fatigue is a common form of failure in rotating shafts because they are subjected to very high cycles and they often have minimal fillets (rounded corners). The latter is often due to space constraints and creating generous radii often means removing a lot of material in manufacturing.

There are many references that provide formulas for stress concentrations.¹ The figures, from pages 5-23 to 5-25 show how FEA can highlight regions of high stress, but they also show that the stress concentration factor is typically about 2 for modestly radiused feature interfaces. This may seem like a modest number, but this depends on the type of loading. For a beam where the strength is proportional to the height squared, increasing the radius of curvature at the interface by a factor of 2 could reduce the stress concentration from 2 to 1.5; hence the height of the beam could drop by $(2/1.5)^{1/2} = 1.15$. Over the length of a long beam, this can result in significant material savings.

A machine for a robot design contest may not seem like it would be subject to high cycle fatigue, but high loads, small parts, and stress concentrations can cause low-cycle fatigue failures. Do you have plastics subject to high stress that may creep? Systematically trace all loads through the structural loops and evaluate their magnitude and number of cycles. Where are the high-risk areas, and what are your countermeasures or plans to reduce the risk?

1. See for example, Roark & Young Formulas for Stress and Strain, 5th edition, pages 590-603

Strength: *Life, Fatigue and Stress Concentration*

- Fatigue: To obtain “infinite” life (endurance limit) in a steel structure
 - Applied stress should be less than ½ yield stress
 - Aluminum has no endurance limit: Infinite life requires zero stress
- Continuous (preload) and alternating stresses can be applied, so use preload to:
 - Minimize the ratio of alternating stress to constant stress
 - Never let the stress alternate between positive and negative

- Stress concentration:
 - Stresses must flow around features, and the sharper the feature, the more severe the *turn*
 - This causes a *kink*, and the stress rises

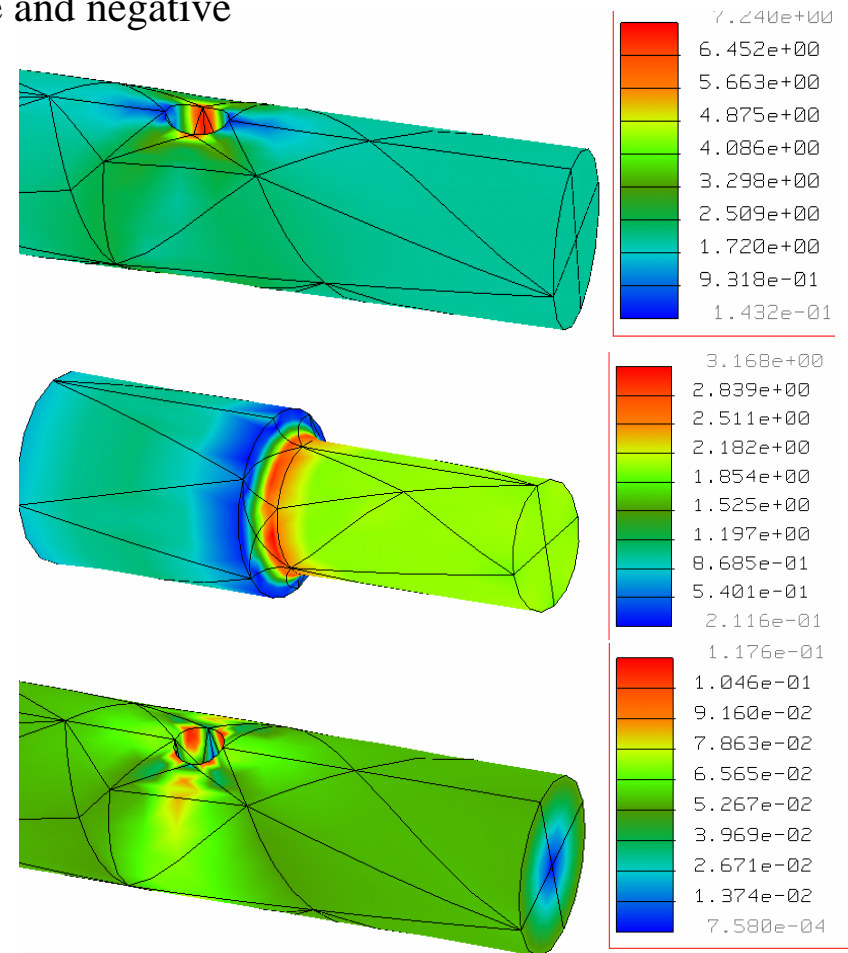
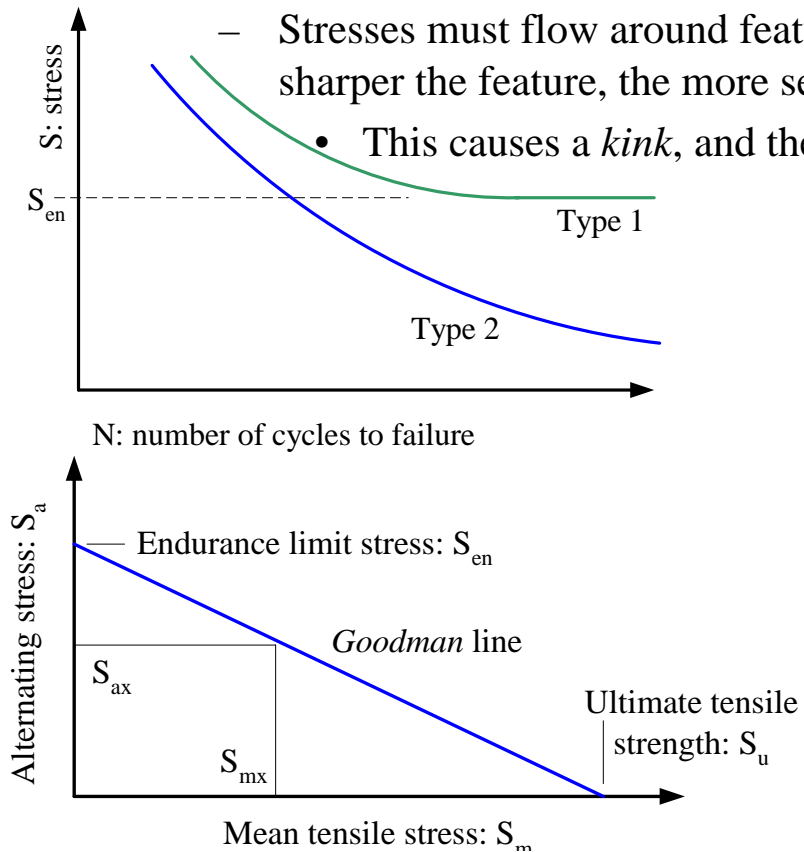

Trusses

Often one needs a large area or length spanned, but with minimal weight and cost. Wide flange beams, such as I-beams shown on page 8-18 are often used because they place most of the beam's mass far away from the neutral axis where it does the most good. However, when even greater strength-to-weight ratios are needed, design engineers often turn to trusses. A truss is essentially a beam where all the extra material has been removed (remember Maudslay!). Since it would be costly to remove lots of material in most cases, trusses are often made from individual elements, such as tubes, that are fastened together with bracing elements. This gives a truss its characteristic zig-zag shape. Trusses are often welded together; however, many large bridge trusses are still manufactured from bolted-together members.¹

There are many websites that feature truss-design programs, many of which are free. Check them out! However, is there a way to rapidly determine if a truss is appropriate for an application? The *Parallel Axis Theorem* comes to the rescue. A truss typically has two members in the *top chord* and two in the *bottom chord*. Where extreme efficiency is required, only one element is used for the top (tensile) chord and two are used for the bottom chord to better resist buckling (see Pages 8-14 and 5-23). The triangular shape can still have sufficient lateral and torsional stiffness. When creating formulas for quick estimation of truss strength, all one needs is the cross-sectional area of the chord. When considering buckling of the chords, the cross-section detail, a tube for example, must be known. For a simple 4-chord truss of height H , chord cross sectional area A , and chord moment of inertia I_A through the A 's neutral axes:

$$I = 4 \left(I_A + A \left(\frac{H}{2} \right)^2 \right) = 4I_A + AH^2 \approx AH^2 \quad \frac{I}{c} = 2AH$$

For a 3-chord truss, the upper chord may not always have the same area as the lower chord members, and the neutral axis location with respect to the bottom chord (distance c) must first be found:

$$y_{NA} = \frac{A_U H}{A_U + 2A_L}$$

$$I = 2I_L + I_U + A_U (H - y_{NA})^2 + 2A_L y_{NA}^2 \approx A_U (H - y_{NA})^2 + 2A_L y_{NA}^2$$

In these equations, I/c can be used with the bending moment to obtain a reasonable estimate of the stress in the top and bottom chords. Given the stress and the chord cross sectional area, the tensile force in the top chord and the compressive force in the bottom chord can be determined. A buckling analysis can then be done. Very conservatively, the buckling analysis can assume simply supported boundary conditions for the chord segment. Of course there is a truss design spreadsheet *Truss.xls* that the reader may want to try! However, these equations are not very good at predicting displacement of a truss. FEA or energy methods can be used for determining displacements.

The purpose of the braces is to transfer stresses between the top and bottom chords, while reducing the free-span of any chord in compression to minimize the chance of buckling. It is relatively straightforward to create a free-body diagram for each member and solve for the forces in each member. One could then ideally optimize the brace design. However, this can only be done if the members are assumed to be pinned at their ends, and since the members are generally long and thin, this is not a bad assumption. Since there are so many web-based truss design programs available, it is rare that an engineer will need to do this analysis. For very large trusses, finite element analysis tools come to the rescue.

Each side of a truss is called a *bent*, and the bents are then assembled to form the truss. Note the fabricated elements shown in the figures, and how the braces have been made from a continuous piece of metal that has been bent into a zig-zag shape prior to being spot welded to the chords. Many large trusses for buildings are manufactured in a similar fashion, where angle sections are then welded to either side of the zig-zag braces.

Take a look around at trusses in cranes, bridges, and buildings. Notice the many different types of bracing. Where might you use a truss in your machine? Experiment with *Truss.xls* to play "what if" scenarios.

1. Bolted connections have a lingering advantage over welded connections: It is difficult for a crack to form that can run through a bolted joint.

$$I_{NA} = I_{zz} + Ay^2_{z-NA}$$

Trusses

$$y_{NA} = \frac{\sum_{i=1}^N E_i A_i y_i}{\sum_{i=1}^N E_i A_i}$$

- Trusses can carry huge loads while being very light weight
 - Saint-Venant & trusses
 - Web member (braces) spacing is typically on the order of the truss height
 - Greater spacing leads to greater deflections and greater chance of chord buckling
 - Fundamentally, the farther away from the neutral axis you can add area, the better squared you will be!
 - Trusses are easily fabricated from spot-welded steel welding rod!

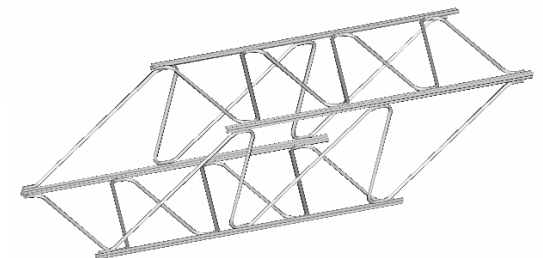
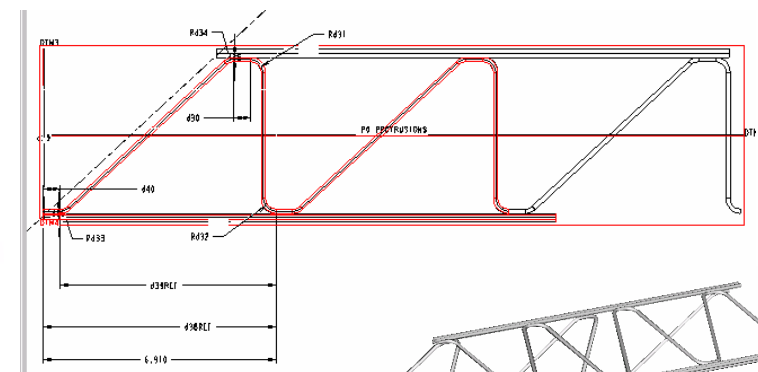
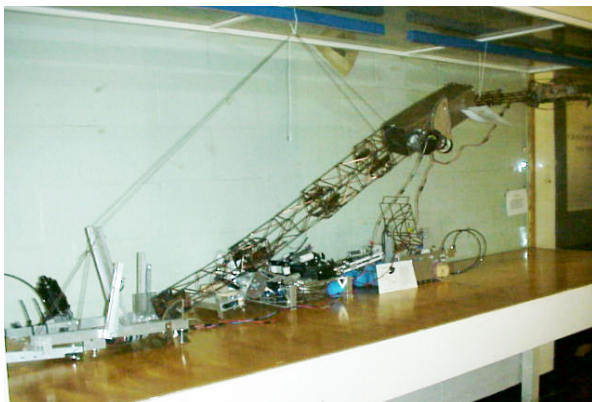
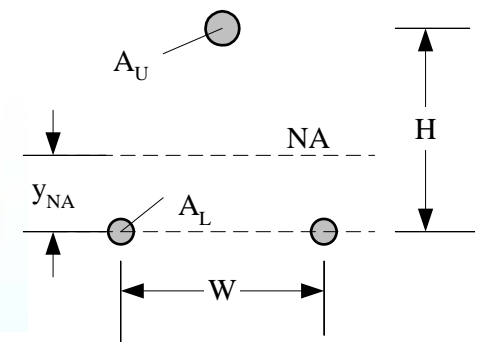
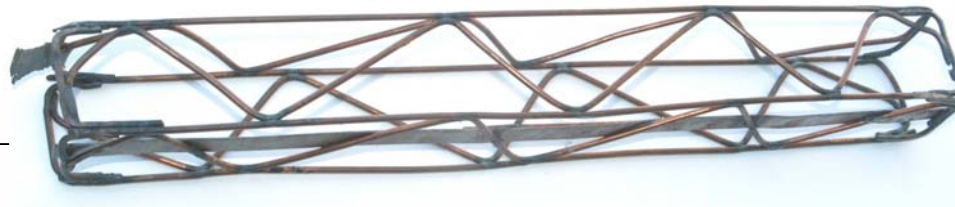
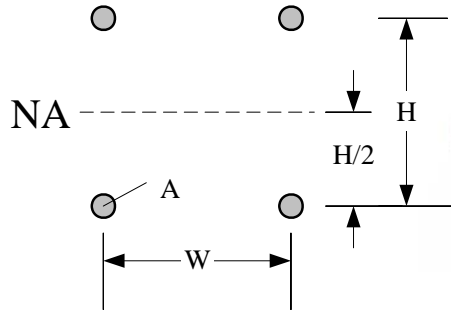

Laminates & Composites

A *laminate* is a structure comprised of thin strong layers of material bonded to a lighter material whose primary purpose is to separate the stronger layers and thereby make use of the parallel axis theorem to achieve high strength and light weight. A *composite* is a material formed from high-strength members, generally small fibers, bonded together with an adhesive matrix. Often, composite layers are bonded to a soft core, as is done with snowboards!

One of the principle calculations needed for the design of laminates or composites is that of the overall effective moment of inertia, the bending stress, and the shear stress. The tensile/compressive stress profile in a beam regardless of its shape is linear, from the maximum tensile (+) stress to the maximum compressive (-) stress. In addition, there are shear stresses through the section of the beam, and it turns out that the profile is parabolic, with zero shear at the top and bottom of the beam. The derivation of the shear stress in a symmetrical beam is the subject of many a strength of materials textbook, and in summary, it is determined from the shear force (dM/dx), the moment of inertia I_{zz} with respect to the beam cross section, and the first moment of the area of interest about the neutral axis:

$$I_{zz} = \int_A y^2 dA \quad Q = \int_{A1} y dA \quad \tau_{yx} = \frac{VQ}{bI_{zz}}$$

For a simple cantilevered rectangular beam of height h and width b , the shear stress at a distance y from the neutral axis is given by:

$$Q = \left(\frac{h/2 - y}{2} + y \right) \left(\frac{h}{2} - y \right) b = \frac{h^2 - 4y^2}{8} b \quad I_{zz} = \frac{bh^3}{12}$$

$$\tau_{xy} = \frac{VQ}{bI_{zz}} = \frac{3V(h^2 - 4y^2)}{2bh^3}$$

A parabolic distribution shows the shear stress is zero at $y = \pm h/2$ and a maximum at $y = 0$, where it is simply $3V/2bh$. When two sheets of high strength material of thickness t are bonded to a low-strength core, whose main purpose is to separate the high strength sheets, the shear stress of interest is at

the bond layer. Neglecting the core, a reasonable assumption, and assuming the sheet thickness is much less than the core thickness, the shear stress at the bond layer is found from:

$$Q = \left(h - \frac{t}{2} \right) bt \quad I_{zz} = \frac{b(h^3 - (h-2t)^3)}{12} \approx \frac{bht(h-2t)}{2}$$

$$\tau_{xy \text{ bond layer}} \approx \frac{V(h-t)}{bh(h-2t)}$$

When determining the equivalent state of stress in an I-beam, note that the maximum bending stress is at the flange outer surface and the maximum shear stress is at the center of the web; thus do NOT use both stresses in the Von-Mises criteria.

What about plywood? The plies are strong in one direction, and weak in the orthogonal direction. By stacking the plies up orthogonal to each other, one acts as a core to the other and a strong and nearly *isotropic* structure is obtained from normally *anisotropic* plies. The above theory still applies for shear stresses, and additional stiffness and strength properties of a laminate can be estimated from:

$$y_{NA} = \frac{\sum y_i E_i A_i}{\sum E_i A_i} \quad EI_{\text{laminate}} = \sum E_i I_i + (y_i - y_{NA})^2 E_i A_i$$

$$I_{\text{estimate for calculating stress in a particular layer}} \approx \frac{EI_{\text{laminate}}}{E_{\text{modulus for the layer of interest}}}$$

These expressions are for estimation purposes only. They are probably good enough for most robot design contests; however, for a production device, finite element analysis should be used. *Laminate.xls* allows you to experiment with the stiffness of a piece of plywood by itself, with metal on one side, or with metal on two sides. Compare this with two sheets of metal bonded to a foam core.

Is plywood good enough for your vehicle base, or would a layer of metal not only add stiffness, but aid in manufacturability? It is easier to precisely locate a hole in metal than in wood.

Laminates & Composites

- Laminates are made of stress-carrying elements bonded to a core (see *Laminate.xls*)
 - They have tensile/compressive carrying members on the outside (chords), and a shear carrying member (core) on the inside
 - Metal chords with a wood core can give nearly the strength of an I beam
 - The shear stresses in the adhesive and core materials must be carefully considered
- Composites use a matrix, typically a polymer such as epoxy, to bond together structural fibers, cloth...
 - Thin composite members are then often laminated to a core...

Simple Plate		
t	0.0625	thickness
w	1	width
L	10	length
E	1.00E+07	modulus
maxstress	20000	
I	2.03E-05	
A	6.25E-02	
loc	6.51E-04	
Fmax	1.30	
deflection	2.13	
Sandwich beam (2 plates with wood core) Assume I and E of wood core are ignored		
tcore	0.5	
Icore	0.0099	
locore	0.0318	
Fmaxcore	63.5	
deflection	0.21	

Drill holes in plywood to reduce weight of laminate core



Solid plywood

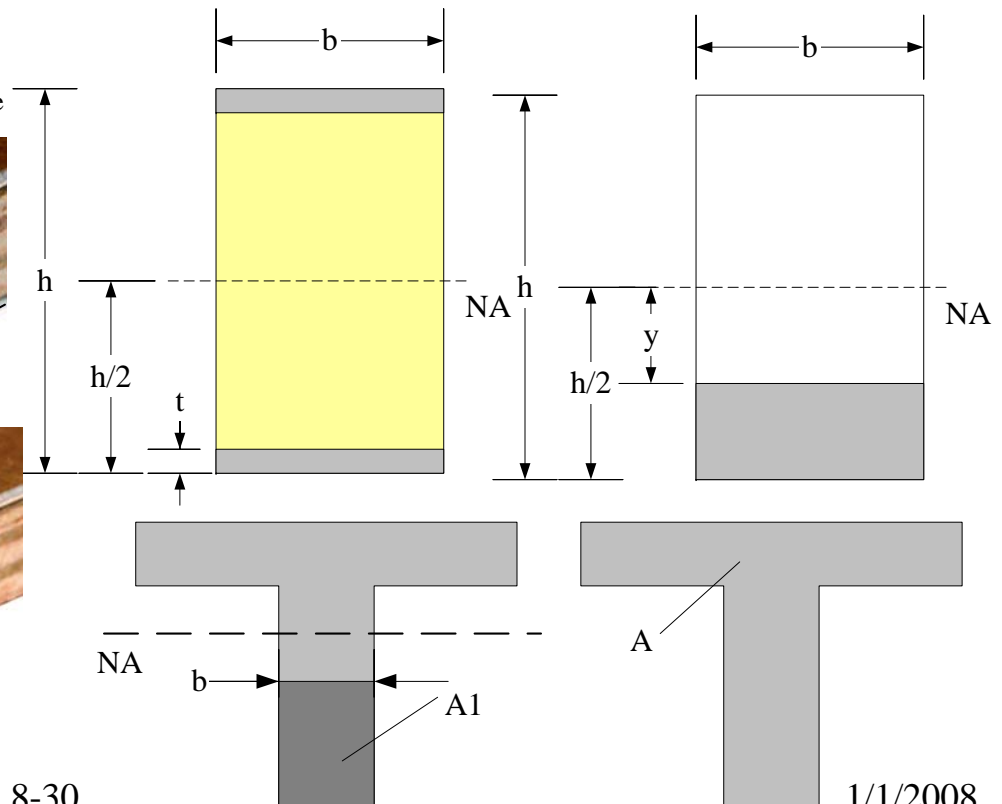

Topic 8 Study Questions

Which suggested answers are correct (there may be more than one, or none)?
Can you suggest additional and/or better answers?

- When the first sketch of the structure is made, arrows indicating forces, moments, and flow of power should also be sketched:
True
False
- Arrows which indicate the path of force flow from the point of action to the point of reaction, which shows the structural loop:
True
False
- A closed structural loop indicates high stability and the likely use of symmetry to achieve a robust design:
True
False
- An open structural loop is not bad, it means “proceed carefully”:
True
False
- Wiring, hoses, and cable carriers can all be added by manufacturing personnel because drawing them is never accurate and assembly people know best:
True
False
- Planning for placement of wiring, hoses, cable carriers, guards, and sensors, is often best done during the concept development phase of a machine:
True
False
- Materials make the machine just as sure as any creative design, and are often selected based on strength, stiffness, manufacturability, and wear and corrosion resistance:
True
False
- Metals have very high strength-to-weight ratios and are easily machined formed, and joined:
True
False
- Wood has high directional strength/weight and is easily joined:
True
False
- Plastics can have good structural and low friction & wear-resistant properties and are easily molded, formed, machined:
True
False
- Axial, torsion, and bending loads can be applied to structures and components, so an equivalent stress needs to be determined and compared to the material’s yield stress:
True
False
- A good process for designing a robust structure is to sequentially imagine that each element of the design is a piece of rubber, while other elements are steel and then apply forces to the system and see how it deforms:
True
False
- Bracing elements with triangles (plate-type gussets or beam-type trusses) are the most efficient method for strengthening a structure:
True
False
- Layout is used to initially define relative placement of elements and the supporting structure and is the first embodiment of the design intent and defines boundaries on the structure:
True
False
- A Layout Drawing is the graphical interpretation of the FRDPARRC table’s Design Parameters:
True
False

16. A sketch & notes can suffice for an initial layout, & serve as a road map for creating a solid model
 True
 False
17. A solid model can serve as a layout, as long as one takes care to not add a lot of detail
 True
 False
18. Motion diagrams and stick figures to help define and select your concept as initial starting points for your layout:
 True
 False
19. A layout can help the designer understand how the structural loop behaves by enabling the designer to:
 Sequentially imagine each component is made of a soft material and visualize deformations
 Estimate deflections, stresses, and vibration modes by performing first order calculations to size members and components
 If the machine is complex, Finite Element Analysis (FEA) may also be used
 If analysis is too costly (e.g., time to do), do a Bench Level Experiment
 Use trial and error to arrive at a workable solution
 Way oversize all the elements to be sure the design will work
20. In order to create an appropriate level-of-detail solid model layout drawing use FRDPARRC tables (from Strategy, to Concept, to Modules, to Components) to understand what functions the structure must perform and then start the design of the structure:
 Start with a hand sketch that captures the ideas swirling about in your brain
 Label principle design parameters (elements) that meet the design intent
 Identify the structural loop and understand its critical points
 Use first order analysis to initially size members
 Create minimal detail solid model components and assemble them using reference planes where possible to maximize the robustness of the model
21. For two wheel drive vehicles, the rear wheels have to push hard enough to make the front wheels climb the obstacle:
 True
 False
22. For four wheel drive vehicles, the rear wheels also provide the normal force needed for the front wheels to apply a tractive effort to help climb over the obstacle:
 True
 False
23. Rather than using brute force, it is generally better to climb an obstacle one wheel at a time
 True
 False
24. Because there are always obstacles, it is a good idea to design in a suspension into a vehicle so it can conform to the terrain:
 True
 False
25. When will a machine driving up a hill tip over?
 The force vector due to gravity just passes through the rear wheels ground contact points
 The slope angle is equal to the angle of the vector between the rear wheels contact point with the ground and the center of mass
26. Axial tension or compression is the applied force directly acts on the material to cause tension or compression
 True

- False
27. Bending is an applied force acts via a lever to bend a beam, causing tension on one side and compression on the other side of the structure
True
False
28. Torsion is a torque (e.g., twisting or two equal and opposite forces applied about a point) causes twist of the structure
True
False
29. Shear is two equal and opposite essentially colinear forces act perpendicular to a structure
True
False
30. All structures deform under load so:
Make sure that the deformations which create translational and angular displacements do not cause other elements to become overloaded or interfere and then fail
Make deflections 3-5x LESS than critical clearances (Saint-Venant)
Try to make forces between members transmitted without causing twisting
Position interface contact points at neutral axis planes
31. System compliance = sum of structural and element compliances, so:
Machine elements (e.g., bearings) and joints should have a stiffness on the order of the structure itself
During the early design stage, before bearings and joints are designed, assume net stiffness will thus be structural stiffness/3
Use steel whenever possible
32. Complex systems can often be modeled by superimposing simple models
True
False
33. Stress=Moment*distance of farthest fiber from Neutral axis/Moment of Inertia:
True

- False
34. Torsional shear stress=Torque*radius/polar moment of inertia
True
False
35. Stresses caused by multiple loads can be combined into an equivalent stress by the von Mises equivalent stress formula:

$$\sigma_{\text{equivalent}} = \sqrt{\frac{\sigma^2 + 3\tau^2}{2}}$$

36. Fatigue: To obtain “infinite” life (endurance limit) in a steel structure
Applied stress should be less than ½ yield stress
Aluminum has no endurance limit: Infinite life requires zero stress
Steel should be used whenever possible
37. Continuous (preload) and alternating stresses can be applied, so use preload to:
Minimize the ratio of alternating stress to constant stress
Never let the stress alternate between positive and negative
Keep the continuous stress at ½ yield stress
38. Stress concentration results in corners:
Stresses must flow around features,
The sharper the feature, the more severe the turn
Aluminum structures are less subject to stress concentration because aluminum is softer than steel
39. A structure can be made much stiffer by using heat treated alloy metals:
True
False
40. Heat treated alloy metals often have a significantly greater modulus of elasticity than non heat treated alloy metals:
True

- False
41. Trusses can carry huge loads while being very light weight, and Saint-Venant's principle can be used to initially layout a truss:
 Web member (braces) spacing is typically on the order of the truss height
 Greater spacing leads to greater deflections and greater chance of chord buckling
 Strength increases the farther away from the neutral axis you can add chord area
 The ratio of chord mass to brace mass should be 3-5
42. The neutral axis theorem can be used to initially size a square cross section truss of height h , width b , and each of four chords having a cross sectional area of A , where the effective second moment of the area of the truss to model it as a beam can be estimated by:
 $I = 4 * A * (h/2)^2$
 $I = 4 * A * b * h^3 / 12$
43. Laminates have tensile/compressive carrying members on the outside (chords), and a shear carrying member (core) on the inside
 True
 False
44. Metal chords with a wood core can give nearly the strength of an I beam
 True
 False
45. The shear stresses in a laminate's adhesive and core materials must be carefully considered
 True
 False
46. Cast iron is always the best choice for a machine tool structure if it can be obtained in time:
 True
 False
47. Welded steel structures are always the most economical for short-turn-around-delivery:
 True
- False
48. Polymer concrete is always the best choice for high volume small-to-mid-size machine structures:
 True
 False
49. Structures made from polymer concrete always have the highest damping:
 True
 False
50. Structures made from welded steel always vibrate excessively:
 True
 False
51. Machine structures should be selected on the basis of cost, manufacturability of the entire system, structural performance (including thermal and dynamic), and delivery time:
 True
 False
52. Thermal expansion errors of a structure are typically the most difficult to control and often one of the greatest sources of error in a machine:
 True
 False
53. Temperature control of a machine can be achieved by:
 Putting the machine in a temperature controlled room
 Insulating the exterior of the machine and isolating heat sources
 Preventing infrared light from reaching the machine by hanging PVC curtains between the machine and light sources in the room
 Circulating temperature controlled fluid through the machine
54. Heat can often be prevented from being transferred to the machine from chips generated by the cutting process by using a flood of coolant to wash the chips away:
 True
 False
55. Heat is *best* prevented from getting into a machine from the process by:
 Isolating the machine from the process as much as possible
 Using sheet metal shields to prevent radiant, convective, and conductive heat transfer

Using gutters, which do not contact the structure to collect coolant and process generated debris

Using low coefficient of thermal expansion materials

56. An actuator attached to a system at its center of stiffness will minimally cause angular motion errors and thus result in a more robust design:

True

False

57. Thermal error can be very difficult to characterize because of the many indifferent ways heat can be transferred, and long time constants:

True

False

58. The best strategy for dealing with thermal error is to minimize and isolate heat sources:

True

False

59. Insulating structural members can help reduce thermal errors:

True

False

60. Since sensors do not generate appreciable heat, there is no need to insulate sensor support structures to help reduce thermal expansion errors:

True

False

61. Infrared heat can be prevented from being transmitted from lights to sensitive machines by shielding the machine from direct light sources using clear PVC plastic curtains:

True

False